



US007687302B2

(12) **United States Patent**
Fossum et al.

(10) **Patent No.:** **US 7,687,302 B2**
(45) **Date of Patent:** ***Mar. 30, 2010**

(54) **FRAME SHUTTER PIXEL WITH AN ISOLATED STORAGE NODE**

(75) Inventors: **Eric R. Fossum**, La Crescenta, CA (US);
Sandor L. Barna, Pasadena, CA (US)

(73) Assignee: **Aptina Imaging Corporation**, Grand Cayman (KY)

(*) Notice: Subject to any disclaimer, the term of this patent is extended or adjusted under 35 U.S.C. 154(b) by 0 days.

This patent is subject to a terminal disclaimer.

(21) Appl. No.: **12/149,902**

(22) Filed: **May 9, 2008**

(65) **Prior Publication Data**

US 2008/0210996 A1 Sep. 4, 2008

Related U.S. Application Data

(60) Continuation of application No. 10/623,533, filed on Jul. 22, 2003, now Pat. No. 7,388,239, which is a division of application No. 09/792,634, filed on Feb. 23, 2001, now Pat. No. 6,624,456.

(60) Provisional application No. 60/184,501, filed on Feb. 23, 2000.

(51) **Int. Cl.**
H01L 127/146 (2006.01)

(52) **U.S. Cl.** **438/60; 438/54; 257/291; 257/292; 257/E27.128; 257/E27.132**

(58) **Field of Classification Search** **257/291-292, 257/223, 294, 225; 438/60, 54**
See application file for complete search history.

(56) **References Cited**

U.S. PATENT DOCUMENTS

4,087,833 A 5/1978 Tseng
5,541,402 A 7/1996 Ackland et al.

5,587,596 A 12/1996 Chi et al.
5,869,857 A 2/1999 Chen
5,900,623 A 5/1999 Tsang et al.
5,986,297 A 11/1999 Guidash et al.
6,025,210 A 2/2000 Matsuda et al.
6,051,857 A 4/2000 Miida
6,069,376 A 5/2000 Merrill
6,087,686 A 7/2000 Fox et al.
6,160,281 A 12/2000 Guidash
6,160,282 A 12/2000 Merrill
6,215,113 B1 4/2001 Chen et al.
6,218,692 B1 4/2001 Guidash et al.
6,326,230 B1 12/2001 Pain et al.
6,369,853 B1 4/2002 Merrill et al.
6,380,572 B1 4/2002 Pain et al.
6,498,622 B1 12/2002 Nakashiba
6,618,086 B1 9/2003 Kawahara et al.

(Continued)

FOREIGN PATENT DOCUMENTS

JP 9-266297 10/1997

(Continued)

Primary Examiner—A. Sefer
(74) *Attorney, Agent, or Firm*—Dickstein Shapiro LLP

(57) **ABSTRACT**

A frame shutter type device provides a separated well in which the storage node is located. The storage node is also shielded by a light shield to prevent photoelectric conversion.

11 Claims, 3 Drawing Sheets

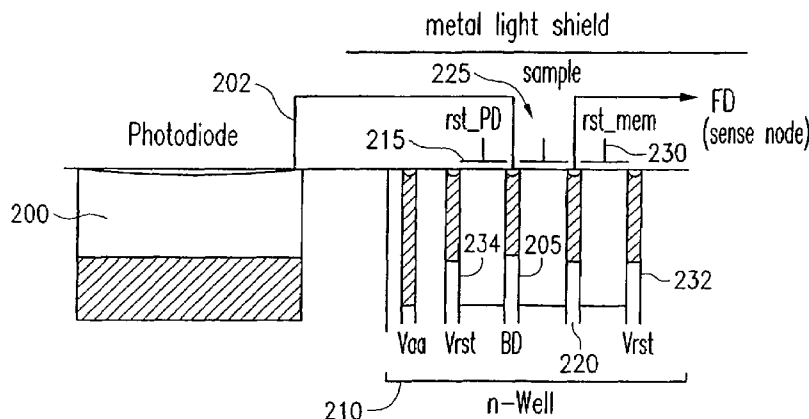

US 7,687,302 B2

Page 2

U.S. PATENT DOCUMENTS

6,778,213 B1 8/2004 Nakashiba
6,859,227 B1 2/2005 Andersson et al.
7,122,397 B2 * 10/2006 Lim 438/60
7,388,239 B2 * 6/2008 Fossum et al. 257/225
2002/0011551 A1 1/2002 Nair
2002/0022295 A1 * 2/2002 Pan 438/57

2007/0257281 A1 * 11/2007 Koizumi et al. 257/225

FOREIGN PATENT DOCUMENTS

JP 9-275201 10/1997
JP 11-274463 10/1999
WO WO-97/28558 8/1997

* cited by examiner

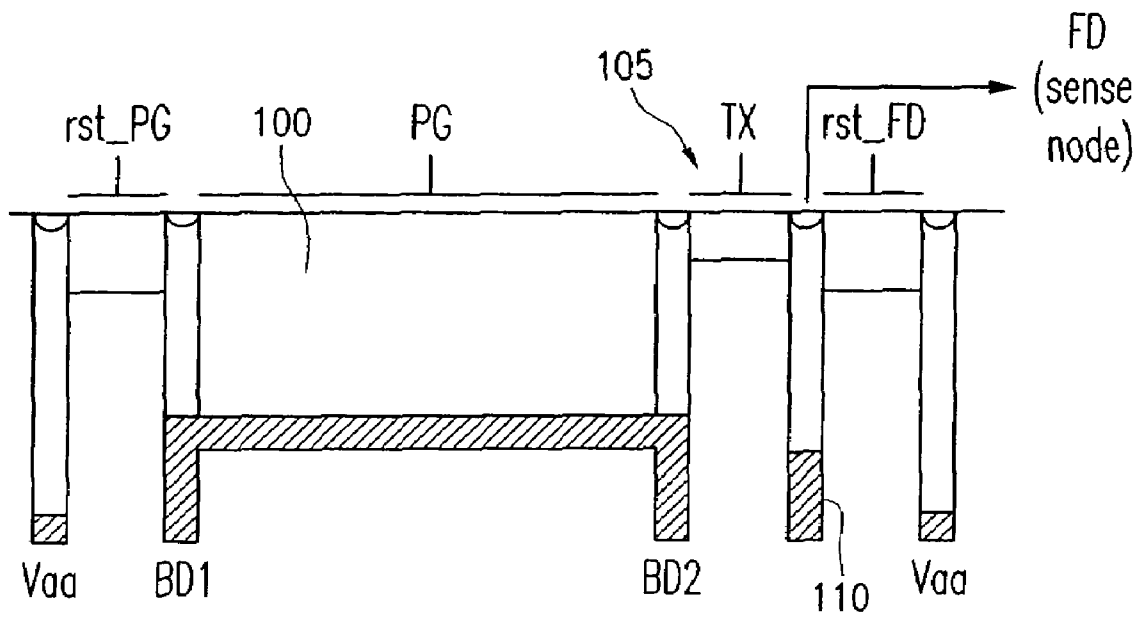

FIG. 1

PRIOR ART

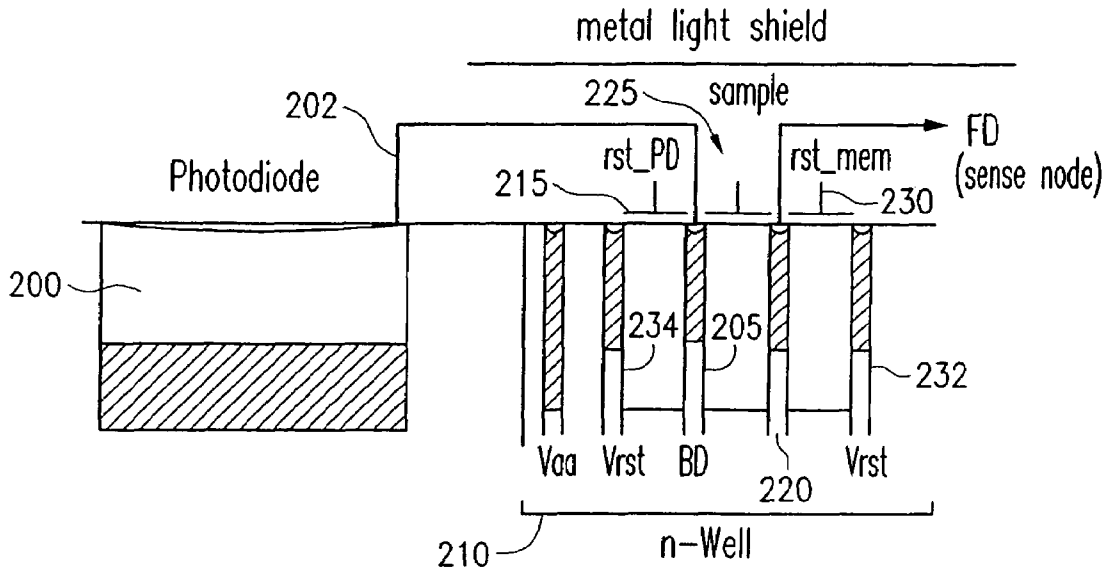

FIG. 2A

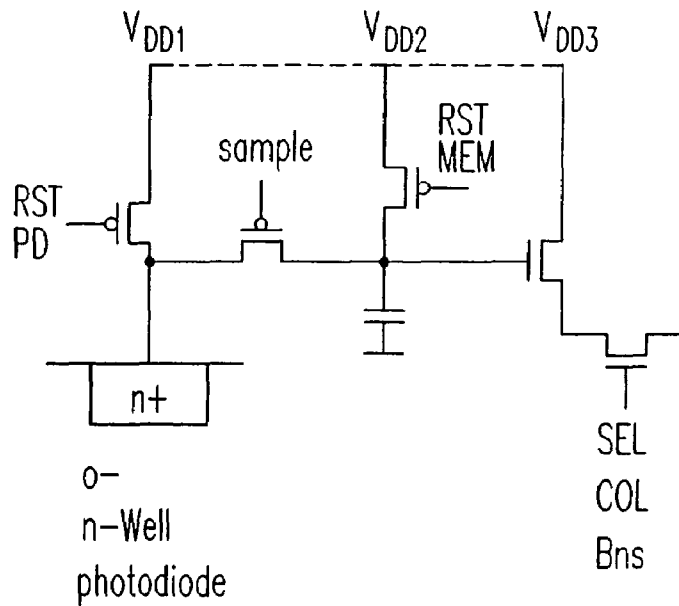

FIG. 2B

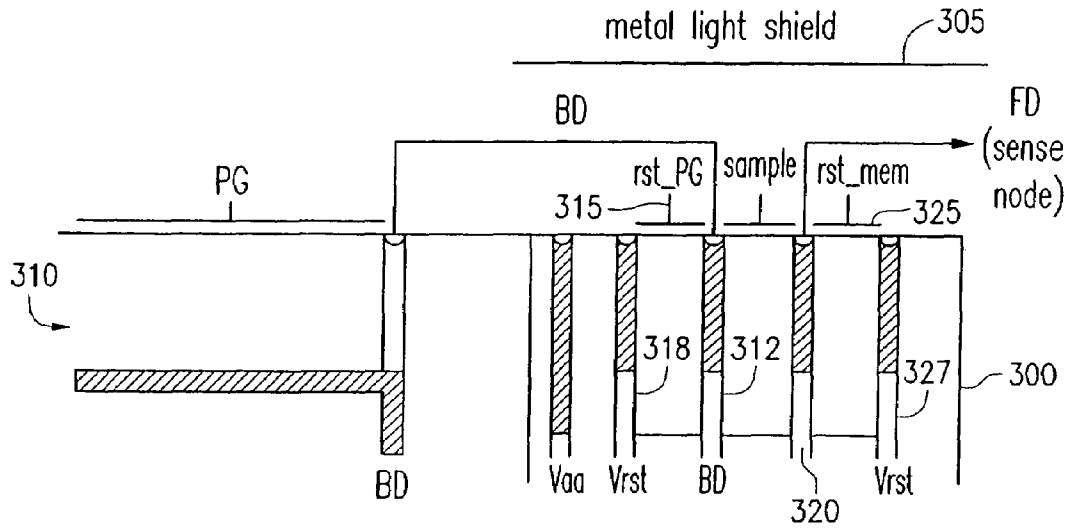

FIG. 3

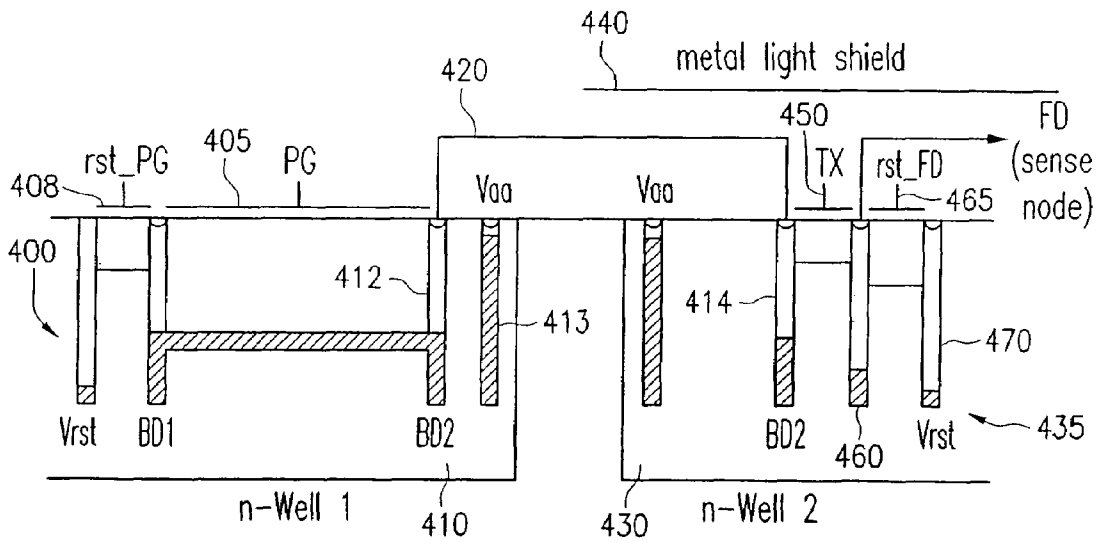

FIG. 4

FRAME SHUTTER PIXEL WITH AN ISOLATED STORAGE NODE

CROSS REFERENCE TO RELATED APPLICATIONS

The present application is a continuation application of U.S. patent application Ser. No. 10/623,533, filed Jul. 22, 2003 now U.S. Pat. No. 7,388,239, which is a divisional application of U.S. patent application Ser. No. 09/792,634 now U.S. Pat. No. 6,624,456, filed on Feb. 23, 2001, which claims priority to provisional Application No. 60/184,501, filed Feb. 23, 2000, the disclosures of which are herewith incorporated by reference in their entireties.

BACKGROUND

CMOS active pixel image sensors may be operated using a "rolling" shutter. Such a shutter operates by reading out each row of pixels, and then resetting that individual row, and then rolling to read and then reset the next row of pixels. Each pixel hence gets read and then reset at slightly different times. Hence, each pixel has a slightly different time of integration. Some applications, such as high-speed photography, may require more time consistency than is possible using this approach. Therefore, in these other applications, a frame shutter may be used. In the frame shutter mode, all pixels in the array have substantially identical integration start times and integration stop times.

A frame shutter technique, using a photogate pixel with two transfer gates, is shown in FIG. 1. A bridge diffusion isolates the photogate PG from the floating diffusion sense node (FD). Hence the charge in the photogate may be integrated and reset independently. The charge is stored in a storage node **110**, which may also be independently reset. Bridge diffusion **BD2** isolates the photogate from the storage node. A second bridge diffusion **BD1** isolates the photogate collection area from a reset level V_{aa} . The charge level in the photogate collection area **100** may be transferred to a storage node **110** via transfer gate **105**.

This isolation allows the integration regions of all the photogates in the entire array to be clocked globally. The same timing therefore exists for each of the plurality of pixels in the array. Moreover, the charge is preserved until the desired time of readout. This enables the active pixel sensor can be read out row by row, thereby allowing the same readout structure as is currently used.

SUMMARY

The present application teaches a new structure which isolates the storage node in order to provide a better image quality in the resultant structure.

BRIEF DESCRIPTION OF THE DRAWINGS

These and other aspects will now be described in detail with reference to the accompanying drawings, wherein:

FIG. 1 shows a traditional photogate frame shutter;

FIGS. 2A and 2B shows a first frame shutter with an isolated storage node with a photodiode;

FIG. 3 shows a second frame shutter with an isolated storage node using a photogate; and

FIG. 4 shows an dual well embodiment.

DETAILED DESCRIPTION

The present inventors have recognized that a problem may occur with the conventional technique shown in FIG. 1. This

problem may result from charge collection by the storage node **110**. The storage node **110** may itself behave like a small photodiode. As such, the storage node **110** may collect some of the charge which is not collected by the photogate **100**. This charge may be collected during the entire storage and/or readout time. This integration uses the rolling shutter type, providing a different readout period for each row of pixels. Hence, the entire storage time may typically be much longer than the desired frame shutter integration time. This leakage may correspond to image smear, and also may become more severe as the photogate size is reduced to make smaller pixel sizes.

According to the present system, embodiments of which are disclosed herein, the storage node is placed inside a protected area. For example, the storage node, which is the node that stores the photoelectrically induced signal, i.e. the charge from the photoreceptor after the charge integration time, may be placed inside an N type well that is protected by a light shield, e.g., a metal light shield. The shield has the effect of preventing a light induced signal from effecting the amount of charge stored in the storage node. The shield may prevent photons from converting into a photoelectric signal such as charge within the N well.

Any charge that is generated in the other regions of the pixel that diffuses to the N well boundary, will be swept into the well contact and hence will never reach the storage node. Of course, small leakage signals may still exist. The signals result primarily from photons which reach the N well as a result of multiple reflections. This is substantially reduced as compared with the kind of conventional system.

FIG. 2A show a first embodiment. FIG. 2A shows a well view of the embodiment, while FIG. 2B shows a transistor level circuit for this embodiment. The pixel in FIG. 2A shown while integrating, with both the photoreceptor **200** and floating diffusion sense node **FD** having been reset. The storage well **220** is still at its reset level; that is the level V_{rst} , as in the reset well **232**.

N-well **210** isolates the wells, including storage well **220**, from the receptor, here photodiode **200**, in the substrate. The isolated wells may include reset diffusions **232**, **234**. The diffusion **234** is a photodiode reset, actuated via NMOS transistor **225**. The floating diffusion reset well **232** is actuated via PMOS transistor **230**.

The photodiode **200** may be a standard n type photodiode. This is electrically connected via **202** to a P-type bridge diffusion node **205** within n type well **210**. The bridge diffusion receives charge from the photodiode.

The photodiode may be reset by lowering the voltage on the gate **215**. This forces both the photodiode and bridge diffusion node **205** to the voltage V_{rst} . When the reset is removed, the photodiode **200** begins to integrate the incoming photoelectric signal. This reduces the voltage on both the photodiode **200**, and the connected bridge diffusion node **205**.

At the end of the integration period, the signal on the photodiode and bridge diffusion well **205** is sampled onto the storage type P node **220**, by lowering the voltage on the sampling gate **225**. The charge is transferred from the photodiode to the storage node in proportion to its relative capacitance. Later, the sample gate **225** is released, and the storage node **220** becomes isolated from any photoelectric current in bridge diffusion **205** by the sample gate **225**. The storage node **220** is also isolated from photoelectric current in the substrate by the N well.

The stored value in the storage node **220** is read out in the traditional method of CMOS active pixel sensor read out.

3

After readout, the storage node **220** is reset to the reset value V_{rst} in well **232**, using the reset memory gate **230**. The stored voltage will be:

$$V_{stored} = V_{rst} - \frac{Q_{photons}}{C_{storage} + C_{bridge} + C_{pd}}$$

The conversion gain is based on the ratio of the storage capacitance to the total capacitance of the storage well **220**+bridge diffusion **205**+photodiode **200**.

In practice, it is important to keep the charge injection substantially identical for each pixel. The charge injection can result from the raising of the voltage on the sample gate and to reset gates. Accurate control of the rise and fall times of the control signals can make sure that this charge injection stays constant.

An alternative embodiment is shown in FIG. **3**. FIG. **3** shows a view of the wells of a single pixel during the integration time. In the FIG. **3** embodiment, a photogate is used as the photoreceptor.

Both the photogate (PG) and the storage node **320** for the floating diffusion sense node (FD) have been reset. The storage node **320** is shown at the reset level in FIG. **3**.

N well **300** is located under a light shield **305**, and the storage node **320** is isolated from the substrate by the N well, as in the embodiment of FIG. **2**. In this embodiment, the photogate **310** is connected to bridge diffusion **312**. The value of the photogate may be reset by activating PMOS gate **315**, to connect the bridge diffusion and photogate to the photogate reset well **318**, which is held at the reset level V_{rst} . Analogously, the storage node is reset by activating PMOS reset memory gate **325**, bringing the storage node **320** to the reset level in storage node reset well **327**.

This embodiment may use a photogate photoreceptor. The photogate allows charge to be collected over the same region as the photodiode pixel as described with reference to FIG. **2**. However, conversion gain may be increased in some situations by lowering the voltage on the photogate in order to force any charge that is present into the bridge diffusions during both the reset of the collection region and during sampling. This may compensate for the capacitance of the photoreceptor, which capacitance can actually be quite significant. Accordingly, the stored voltage can be considered as:

$$V_{stored} = V_{rst} - \frac{Q_{photons}}{C_{storage} + C_{bridge}}$$

This system may therefore increase conversion gain. However, the photogate may have a lower quantum efficiency than the photodiode. Therefore, any advantages of the second embodiment may be offset by quantum efficiency disadvantages.

Another embodiment shown in FIG. **4** forms separated wells, a first well **400** for the photoreceptor **405** and a second well **430** for the readout circuit **435**. This device is shown in charge integration mode, having lower positions corresponding to lower voltages. Holes may be integrated under the photogate **405** to form charge which is stored in one of the bridge diffusions **412** within the photo gate. The photogate is located in the first well **410**. In this embodiment, the photogate may be reset within the first N well **410**. The photogate is reset by activating the gate **408** to bring the photogate level to the reset level V_{rst} . This has the effect of clearing the charge

4

within the photogate **405** as well as the bridge diffusions **412** and **414**. An anti blooming gate **413** may also be located within the first well **410**.

The output of the photogate is connected by a wire **420** to the bridge diffusion **414** within the second N well **430**. The charge may be transferred. The value in the bridge diffusions may also be transferred by the transfer gate **450** to the floating diffusion sensing node. The storage node **460** may be reset independently to the value in reset well **470** by activating the storage node reset gate **465**.

In this embodiment, the gates are formed of P type MOS structures.

This pixel is operated in the same manner as the original photogate frame shutter, but with the signals converted to take into account the P type transistors. The conversion gain is:

$$V_{stored} = V_{rst} - \frac{Q_{photons}}{C_{storage}}$$

as in the above second embodiment, use of a photogate may reduce the quantum efficiency, and hence may offset some of the otherwise-obtained improvements.

Although only a few embodiments have been disclosed in detail above, other modifications are possible. For example, the photoreceptors as disclosed above could be other photoreceptor's besides the ones that are specifically disclosed. In addition, the sense of the semiconductor substrates, that is N type gates and P type gates could be reversed. The N type well could of course be replaced by a P type well.

All such modifications are intended to be encompassed within the following claims, in which:

What is claimed is:

1. A method comprising:

receiving a photoelectrically induced signal in an array of photoreceptors on a semiconductor substrate;

controlling each photoreceptor in the array of photoreceptors to simultaneously initiate a common integration period;

at the end of each integration period, controlling each photoreceptor in the array of photoreceptors to transfer its photoelectrically induced signal to a respective storage node formed in the semiconductor substrate; and

preventing each storage node from integrating charge, wherein each storage node is doped to a first conductivity type, and

wherein a portion of the semiconductor substrate surrounding each storage node is doped to a second conductivity type.

2. The method of claim 1, wherein the act of preventing each storage node from integrating charge comprises shielding each storage node with an overlying light shield.

3. The method of claim 1, wherein the act of preventing each storage node from integrating charge comprises shielding at least the semiconductor substrate surrounding each storage node with an overlying light shield.

4. The method of claim 3, further comprising enabling a first reset operation which resets a value of each storage node, and enabling a second reset operation, which resets a value of each photoreceptor.

5. The method of claim 4, wherein said first and second reset operations each comprises activating a gate within the semiconductor substrate surrounding each storage node.

6. The method of claim 5, wherein each photoelectrically induced signal is a signal indicative of charge produced by a respective photoreceptor during said integration period.

5

7. The method of claim 4, wherein each of the plurality of photoreceptors in the array comprise a semiconductor well.

8. The method of claim 1, further comprising resetting each storage node with a reset transistor provided within the semiconductor substrate surrounding each storage node.

9. The method of claim 8, further comprising removing charge from each photoreceptor with an anti blooming gate located within each semiconductor well.

6

10. The method of claim 1, further comprising transferring charge from each photoreceptor to each storage node with a transfer gate provided within the semiconductor substrate surrounding each storage node.

11. The method of claim 1, further comprising isolating each storage node with a bridge diffusion node located within the semiconductor substrate surrounding each storage node.

* * * * *