



US007105371B2

(12) **United States Patent**
Fossum et al.

(10) **Patent No.:** **US 7,105,371 B2**
(45) **Date of Patent:** **Sep. 12, 2006**

(54) **METHOD OF ACQUIRING AN IMAGE FROM AN OPTICAL STRUCTURE HAVING PIXELS WITH DEDICATED READOUT CIRCUITS**

4,093,872 A	6/1978	Hartman et al.	377/60
4,155,094 A	5/1979	Ohba et al.	257/292
4,287,441 A	9/1981	Smith	307/353
4,309,624 A	1/1982	Hynecek et al.	257/239
4,363,963 A	12/1982	Ando	

(75) Inventors: **Eric R. Fossum**, LaCrescenta, CA (US); **Sunetra Mendis**, Pasadena, CA (US); **Sabrina E. Kemeny**, LaCrescenta, CA (US)

(Continued)

FOREIGN PATENT DOCUMENTS

(73) Assignee: **California Institute of Technology**, Pasadena, CA (US)

EP	0 700 582 B1	7/1998	
JP	5235317	9/1993 257/258

OTHER PUBLICATIONS

(*) Notice: Subject to any disclaimer, the term of this patent is extended or adjusted under 35 U.S.C. 154(b) by 114 days.

S. Chamberlain, "Photosensitivity and Scanning of Silicon Image Detector Arrays," IEEE J. Solid State Circuits, vol. SC-4, No. 6, pp. 333-342 (Dec. 1969).

(21) Appl. No.: **10/712,844**

M. Aoki et al., "2/3 Inch Format MOS Single-Chip Color Imager," IEEE Trans. On Electron Devices, vol. ED-29, No. 4, pp. 745-750 (Apr. 1982).

(22) Filed: **Nov. 12, 2003**

J. Hynecek, "A New Device Architecture Suitable for High-Resolution and High-Performance Image Sensors" IEEE Trans. on Electron Devices, vol. 35(5), pp. 646-652 (May 1988).

(65) **Prior Publication Data**

US 2004/0160522 A1 Aug. 19, 2004

(Continued)

Related U.S. Application Data

(62) Division of application No. 10/388,250, filed on Mar. 12, 2003, now Pat. No. 6,744,068, which is a division of application No. 09/604,846, filed on Jun. 27, 2000, now Pat. No. 6,555,842, and a division of application No. 08/558,521, filed on Nov. 16, 1995, now Pat. No. 6,101,232, and a division of application No. 08/188,032, filed on Jan. 28, 1994, now Pat. No. 5,471,515.

Primary Examiner—Fetsum Abraham

(74) *Attorney, Agent, or Firm*—Fish & Richardson P.C.

(51) **Int. Cl.**

H01L 29/04 (2006.01)

(57)

ABSTRACT

(52) **U.S. Cl.** **438/48**; 438/128; 438/149; 438/151; 438/157; 438/283

(58) **Field of Classification Search** 438/48, 438/128, 149, 151, 157, 283

See application file for complete search history.

An imaging device formed as a monolithic complementary metal oxide semiconductor integrated circuit in an industry standard complementary metal oxide semiconductor process, the integrated circuit including a focal plane array of pixel cells, each one of the cells including a photogate overlying the substrate for accumulating photo-generated charge in an underlying portion of the substrate, a readout circuit including at least an output field effect transistor formed in the substrate, and a charge coupled device section formed on the substrate adjacent the photogate having a sensing node connected to the output transistor and at least one charge coupled device stage for transferring charge from the underlying portion of the substrate to the sensing node.

(56) **References Cited**

U.S. PATENT DOCUMENTS

3,623,132 A 11/1971 Green 377/60

2 Claims, 2 Drawing Sheets

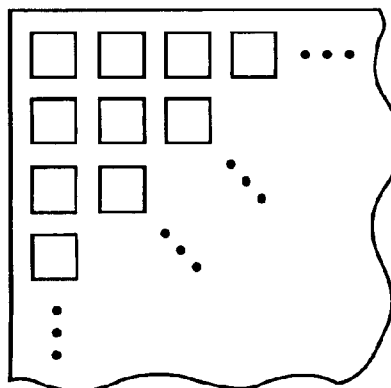

U.S. PATENT DOCUMENTS

4,407,010	A	9/1983	Baji et al.	
4,525,742	A	6/1985	Nishizawa et al.	
4,631,400	A	12/1986	Tanner et al.	
4,660,090	A	4/1987	Hynecek	
4,683,580	A	7/1987	Matsunaga	377/60
4,835,617	A	5/1989	Todaka et al.	
4,839,729	A	6/1989	Ando et al.	
4,839,735	A	6/1989	Kyomasu et al.	
4,859,624	A	8/1989	Goto	257/371
4,942,474	A	7/1990	Akimoto et al.	
4,959,727	A	9/1990	Imaide et al.	
5,097,339	A	3/1992	Ishida et al.	
5,134,488	A	7/1992	Sauer	
5,153,421	A	10/1992	Tandon et al.	
5,182,623	A	1/1993	Hynecek	
5,184,203	A	2/1993	Taguchi	257/370
5,192,990	A	3/1993	Stevens	377/60
5,198,654	A	3/1993	Mukainakano et al.	
5,198,880	A	3/1993	Taguchi et al.	257/370
5,225,696	A	7/1993	Bahraman	
5,262,871	A	11/1993	Wilder et al.	
5,317,174	A	5/1994	Hynecek	
5,323,052	A	6/1994	Koyama	257/294
5,335,015	A	8/1994	Cooper et al.	
5,341,008	A	8/1994	Hynecek	
5,345,266	A	9/1994	Denyer	
5,369,039	A	11/1994	Hynecek	
5,420,634	A	5/1995	Matsumoto	
5,424,223	A	6/1995	Hynecek	
5,436,476	A	7/1995	Hynecek	
5,452,004	A	9/1995	Roberts	
5,452,109	A	9/1995	Compton	
5,471,245	A	11/1995	Cooper et al.	
5,471,515	A	11/1995	Fossum et al.	
5,495,337	A	2/1996	Goshorn et al.	
5,541,402	A	7/1996	Ackland et al.	
5,563,429	A	10/1996	Isogai	
5,585,620	A	12/1996	Nakamura et al.	
5,608,204	A	3/1997	Höflinger et al.	
5,631,704	A	5/1997	Dickinson et al.	
5,652,622	A	7/1997	Hynecek	
6,175,383	BI *	1/2001	Yadid-Pecht et al.	348/302

OTHER PUBLICATIONS

F. Andoh, et al., "A 250,000-Pixel Image Sensor with FET Amplification at Each Pixel for High-Speed Television Cameras," 1990 IEEE International Solid-State Circuits Conference, Digest of Technical Papers, pp. 212-213 (Feb. 16, 1990).

N. Tanaka et al., "A 310K Pixel Bipolar Imager (BASIS)," IEEE Trans. On Electron Devices, vol. 37(4), pp. 964-971 (Apr. 1990).

K. Chen, et al., "PASIC: A Processor-A/D converter-Sensor Integrated Circuits," IEEE ISCAS, pp. 1705-1708 (1990).

O. Yadid-Pecht, et al., "A Random Access Photodiode Array for Intelligent Image Capture," IEEE Trans. on Electron Devices, vol. 38, No. 8, pp. 1772-1780 (Aug. 1991).

M. Kyomasu, "A New MOS Imager Using Photodiode as Current Source," IEEE Journal of Solid State Circuits, vol. 26, No. 8, pp. 1116-1122 (Aug. 1991).

R. Forchheimer, et al., "MAPP2200 -A Second generation smart optical sensor," Proc. SPIE, vol. 1659, pp. 2-11, (1992).

C. Jansson, et al., "An Addressable 256 x 256 Photodiode Image Sensor Array with an 8-Bit Digital Output," Analoga Integrated Circuits and Signal Processing, vol. 4, pp. 37-49 (1993).

H. Kawashima, et al., "a 1/4 Inch Format 250K Pixel Amplified MOS Image Sensor Using CMOS Process," IEEE IEDM Tech. Digest, pp. 22.4.1-22.4.4 (1993).

S. Mendis, et al., "Design of a Low-Light-Level Image Sensor with On-chip Sigma-Delta Analog-to-Digital Conversion," SPIE, Charge Coupled Devices & Solid State Optical Sensors III, vol. 1900, pp. 31-39 (1993).

M. Sugawara, et al., "An Amplified MOS Imager Suited for Image Procassing," (1994 IEEE International Solid-State Circuits Conference, Digest of Technical Papers, Session 13, Neural Networks and Image Sensors/Paper TP 13.6, PP. 228-229 (1994).

B. Fowler, et al., "A CMOS Area Image Sensors with Pixel-Level A/D Conversion," 1994 IEEE International Solid-State Circuits Conference, Digest of Technical Paper, Neural Networks and Image Sensors/Paper TP 13.5, PP. 226-227 (1994).

B. Pain, et al., "Approaches and analysis for on-focal-plane analog-to-digital conversion," Proc. SPIE, vol. 2226, pp.208-218 (1994).

A. Gruss, et al., "Integrated Sensor and Range-Finding Analog Signal Processor," IEEE Journal of Solid State Circuits, vol. 26, No. 3, 184-191 (Mar. 1991).

Renshaw, et al., "ASIC Imager Sensos," Proc. IEEE ISAS, pp. 3038-3041 (1990).

O. Vellacon, "CMOS in camera," IEE Review, pp. 111-114 (May 1994).

I. Muirhead, "Developments in CMOS Camera Technology," published by: IEE Savoy Place, London WC2R 0BL, UK, pp. May 1-May 4 (1994).

I. Takayanagi, et al., "A Multiple Output CMD Imager for Real-Time Image Processing," IEEE, IEDM, pp. 22.5.1-22.5.4 (1993).

M. White, et al., "Characterization of Surface Channel CCD Image Arrays at Low Light Levels," IEEE Journal of Solid-State Circuits, vol. SC-9, No. 1, pp.1-13 (Feb. 1974).

W. Yang, et al., "A fill-fill factor CCD imager with integrated signal processors," IEEE International Solid-State Circuits Conference Digest of Technical Papers, pp.218-219 and 300 (Feb. 16, 1990).

R. Forchheimer, "Single-chip image sensors with a digital processor array," Journal of VLSI Signal Processing, vol. 5, pp. 121-131 (1993).

E. Fossum et al., "Development of CMOS Active Pixel Image Sensors for Low Cost Commercial Applications," Conference Proceedings of NASA Technology 2004, pp. 1-2 (Nov. 1994),3

E. Fossum, "Assessment of Image Sensor Technology for Future NASA Missiions," Proceedings of the SPIE, vol. 2172, Charge-Coupled Devices and Solid-State Optical Sensors IV, pp. 1-16 (1994).

T. Kuriyama et al., "A 1/3-in 270 000 Pixel CCD Image Sensor," IEEE Transation on Electron Devices , Sjpecia Issue on Solid State Image Sensors, vol. 38, No. 5, pp. 949-953 (May 1991).

J. Hojo, et al., "A 1/3-in 510(H) +492(V) CCD Image Sensor with Mirror Image Function," IEEE Transaction on Electron Devices, Special Issue on Solid State Image Sensors, vol. 38, No. 5, pp. 954-959 (May 1991).

H. Ando, et al., "A 1/2-in CCD Imager with Lateral Overflow-Gate Shutter," IEEE Transaction on Electron Devices, Special Issue on Solid State Image Sensors, vol. 38, No. 5, pp. 962-964 (May 1991).

- A. Toyoda, et al., "A Novel Tungsten Light-Shield Structure for High-Density CCD Image Sensors," *IEEE Transaction on Electron Devices, Special Issue on Solid State Image Sensors*, vol. 38, No. 5, pp. 965-968 (May 1991).
- T. Ozaki, et al., "A Low-Noise Line-Amplified MOS Imaging Devices," *IEEE Transaction on Electron Devices, Special Issue on Solid State Sensors*, vol. 38, No. 5, pp. 969-975 (May 1991).
- M. Yanagishi, et al., "A 2 Million Pixel FIT-CCD Image Sensor for HDTV Camera Systems," *IEEE Transactions on Electron Devices, Special Issue on Solid State Image Sensors*, vol. 38, No. 5, pp. 976-980 (May 1991).
- E. Stevens, et al., "A 1-Megapixel, Progressive-Scan Image Sensor with Antiblooming Control and Tag-Free Operation," *IEEE Transactions on Electron Devices, Special Issue on Solid State Image Sensors*, vol. 38, No. 5, pp. 981-988 (May 1991).
- K. Matsumoto, et al., "The Operation Mechanism of a Charge Modulation Devices (CMD) Image Sensor," *IEEE Transactions on Electron Devices, Special Issue on Solid State Image Sensors*, vol. 38, No. 5, pp. 989-998 (May 1991).
- K. Matsumoto, et al., "Analysis of Operational Speed and Scaling Down the Pixel Size of a Charge Modulation Devices (CMD) Image Sensors," *IEEE Transaction on Electron Devices, Special Issue on Solid State Image Sensors*, vol. 38, No. 5, pp. 999-1004 (May 1991).
- M. Ogata, "A Small Pixel CMD Imager Sensor," *IEEE Transactions on Electron Devices, Special Issue on Solid State Image Sensors*, vol. 38, No. 5, pp. 1005-1010 (May 1991).
- Hynacek, "BCMD -An Improved Photosite Structure for High-Density Image Sensors," *IEEE Transactions on Electron Devices*, vol. 38(5), pp. 1011-1020 (May 1991).
- T. Mizoguchi, et al., "A 250 k-Pixel SIT Image Sensor Operating in High-Sensitivity Mode. *IEEE Transaction on Electron Devices, Special Issue on Solid State Image Sensor*," vol. 38, No. 5, pp. 1021-1022 (May 1991)
- Y. Nakamura, et al., "Design of Bipolar Image Device (BASIS)," *IEEE Transaction on Electron Devices, Special Issue on Solid State Image Sensors*, vol. 38, No. 5, pp. 1028-1036 (May 1991).
- M. Miyawaki, et al. "Reduction of Fixed-Pattern Noise of BASIS Due to Low Kinetic Energy-Reactive Ion to Low Kinetic Energy Reactive Ion and Native-Oxide-Free Processing," *IEEE Transaction on Electron Devices, Special Issue on Solid State Image Sensors*, vol. 38, No. 5, pp. 1037-1043 (May 1991).
- Y. Matsunaga, et al., "A High-Sensitivity MOS Photo-Transistor for Area Image Sensor," *IEEE Transaction on Electron Devices, Special Issue on Solid State Image Sensors*, vol. 38, No. 5, pp. 1044-1047 (May 1991).
- N. Mutoh, et al., "New Low-Noise Output Amplifier for High-Definition CCD Image Sensors," *IEEE Transaction on Electron Devices, Special Issue on Solid State Image Sensors*, vol. 38, No. 5, pp. 1048-1055 (May 1991).
- M. Tabel, et al., "A New CCD Architecture of High-Resolution and Sensitivity for Color Digital Still Picture," *IEEE Transaction on Electron Devices, Special Issue on Solid State Image Sensors*, vol. 38, No. 5, pp. 1052-1058 (May 1991).
- J. Bosiers, et al., "A 2/3-in 1187(H) x 581(V) S-VHS-Compatible Frame Transfer CCD for ESP and Movie Mode," *IEEE Transaction on Electron Devices, Special Issue on Solid Image Sensors*, vol. 38, No. 5, pp. 1059-1068 (May 1991).
- B. Burke, "An Abutable CCD Imager for Visible and X-Ray Focal Plane Arrays," *IEEE Transaction on Electron Devices, Special Issue on Solid State Image Sensors*, vol. 38, No. 5, pp. 1069-1076 (May 1991).
- E. Garcia, "CCD Arrays for Readout of Electrophotographic Latent Images," *IEEE Transaction on Electron Devices, Special Issue on Solid State Image Sensors*, vol. 38, No. 5, pp. 1077-1085 (May 1991).
- T. Kaneko, et al., "400 dpi Integrated Contact Type Linear Image Sensors with Poly-Si TFT's Analog Readout Circuit and Dynamic Shift Registers," *IEEE Transaction on Electron Devices, Special Issue on Solid State Image Sensors*, vol. 38, No. 5, pp. 1086-1093 (May 1999).
- C. K. Chen, et al., "Ultraviolet, Visible, and Infrared Response of PiSi Schottky-Barrier Detectors Operated in the Front-Illuminated Mode," *IEEE Transaction on Electron Devices, Special Issue on Solid State Image Sensors*, vol. 38, No. 5, pp. 1094-1103 (May 1991).
- R. B. Bailey, et al., "256 x 256 Hybrid HgCdTe Infrared Focal Plane Arrays," *IEEE Transaction on Electron Devices, Special Issue on Solid State Image Sensors*, vol. 38, No. 5, pp. 1104-1109 (May 1991).
- K. Matsumoto, et al., "Analysis of Operational Speed and Scaling Down on the Pixel Size of a Charge Modulation Device (CMD) Image Sensors," *IEEE Transaction on Electron Devices, Special Issue on Solid State Image Sensors*, vol. 38, No. 5, pp. 999-1004 (May 1991).
- M. Ogata, "A Small Pixel CMD Image Sensor," *IEEE Transaction on Electron Devices, Special Issue on Solid State Image Sensors*, vol. 38, No. 5, pp. 1005-1010 (May 1991).
- H. Zogg, et al., "Infrared Sensor Array with 3-12/μm Cutoff Wavelengths in Heteroepitaxial Narrow-Gap Semiconductor on Silicon Substrates," *IEEE Transaction on Electron Devices, Special Issue on Solid State Image Sensors*, vol. 38, No. 5, pp. 1110-1117 (May 1991).
- C. G. Berbea, et al., "10-μm GaAs/AlGaAs Multiple Quantum Well Hybrid Focal Plane Array," *IEEE Transaction on Electron Devices, Special Issue on Solid State Image Sensors*, vol. 38, No. 5, pp. 1118-1123 (May 1991).
- L. J. Kozlowski et al., "LWIR 128 x 128 GaAs/AlGaAs Multiple Quantum Well Hybrid Focal Plane Array," *IEEE Transaction on Electron Devices, Special Issue on Solid State Image Sensors*, vol. 38, No. 5, pp. 1118-1123 (May 1991).
- M. Denda, et al., "4-Band x 4096-Element Schottky-Barrier Infrared Linear Image Sensor," *IEEE Transactions on Electron Devices, Special Issues on Solid State Image Sensors*, vol. 38, No. 5, pp. 1131-1135 (May 1991).
- S. Tohyama, et al., "A New Concept Silicon Homojunction Infrared Sensor," *IEEE Transaction on Electron Devices, Special Issues on Solid State Image Sensors*, vol. 38, No. 5, pp. 1136-1140 (May 1991).
- T-L Lin, et al., "SiGe/ Si Heterojunction Internal Photoemission Long-Wavelength Infrared Detectors Fabricated by Molecular Beam Epitaxy," *IEEE Transaction on Electron Devices, Special Issue on Solid State Image Sensors*, vol. 38, No. 5, pp. 1141-1144 (May 1991).

- M. Okuyama et al., "Room-Temperature-Operated Infrared Image CCD Sensor Using Pyroelectric Gate Coupled by Dielectric Connector," vol. 38, No. 5, pp. 1145-1151 (May 1991).
- J.G.C. Bakker, "Simple Analytical Expressions for the Fringing Field and Fringing-Field-Induced Transfer Time in Charge-Coupled Devices," IEEE Transaction on Electron Devices, Special Issue on Solid Image Sensors, vol. 38, No. 5, pp. 1152-1161 (May 1991).
- E. K. Banghart et al., "A Model for Charge Transfer in Buried-Channel Charge-Couple Devices at Low Temperature", IEEE Transaction on Electron Devices, Special Issue on Solid State Image Sensors, vol. 38, No. 5, pp. 1162-1174 (May 1991).
- C. R. Hoople et al., "Characterization of Semiconductor Gaps in Buried-Channel CCD Structures, IEEE Transaction on Electron Devices, Special Issue on Solid State Images Sensors" vol. 38, No. 5, pp. 1175-1181 (May 1991).
- E. R. Fossum, et al., "Two-Dimensional Electron Gas Charge-Coupled Devices (2DEG-CCD's), IEEE Transaction on Electron Devices, Special Issue on Solid State Image Sensors," vol. 38, No. 5, pp. 1182-1192 (May 1991).
- J.G.C. Bakker, et al., "The Tacking CCD: A New CD Concept, "IEEE Transaction on Electron Devices, Special Issue on Solid State Image Sensor, vol. 28
- S. Takayama, et al. "A Dynamic Modell of an a-Si:H Photoconductive Sensor," IEEE Transaction on Electron Devices, Special Issue on Solid State Image Sensors, vol. 38, No. 5, pp. 1201-1205 (May 1991).
- P. Centen, "CCD On-Chip Amplifiers: Noise Performance versus MOS Transistor Dimensions," IEEE Transaction on Electron Devices, Special Issue on Solid State Image Sensors, vol. 38, No. 5, pp. 1206-1216 (May 1991).
- N. Ozawa, et al., "A Correlative Coefficient Multiplying (CCM) Method for Chrominance Moire Reduction in Single-Chip Video Cameras," IEEE Transaction on Electron Devices, Special Issue on Solid tate Image Sensors, vol. 38, No. 5, pp. 1217-1225 (May 1991).
- Tsai, Y.T. "Color Image Compression for Single-Chip Cameras," IEEE Transaction on Electron Devices, Special Issue on Solid State Image Sensors, vol. 38, No. 5, pp. 1226-1233 (May 1991).
- P. Noble, "Self-Scanned Silicon Image Detector Arrays," IEEE Trans. on Electron Devices. vol. ED-15, No. 4, pp. 202-205 (Apr. 1968).
- J. Nishikawa, et al., "Static Induction Transistor Image Sensors," IEEE Trans on Electron Devices, vol. ED-26(12), pp. 1970-1977 (Dec. 1979).
- K. Matsumoto, et al., "A New MOS Phototransistor Operating in a Non-Destructive Readout Mode," Jpn. J. Appl. Phys., vol. 24, No. 5, pp. L323-L325 (1985).
- H. Ando, et al., "Design Consideration and Performance of a New MOS Imaging Device," IEEE Trans. on Electron Devices, vol. ED-32, No 8, pp. 1484-1489 (Aug. 1985).
- T. Nakamura, et al., "A New MOS Image Sensor Operating in a Non-Destructive Readout Mode," IEDM Tech. Dig., pp. 353-356 (1986).
- A. Yusa, et al., "SIT Image Sensor: Design Considerations and Characteristic" IEEE. Trans. on Electron Devices, vol. ED-33, No. 6, pp. 735-742 (Jun. 1986).
- N. Tanaka, et al., "A Novel Bipolar Image Device with Self-Noise-Reduction Capability," IEEE Trans. on Electron Devices, vol. 36(1), pp. 31-38 (Jan. 1989).
- Z. Huang, et al., "A Novel Amplified Image Sensor with a-Si:H Photoconductor and MOS Transistor," IEEE Trans. on Electron Devices, vol. 37, No. 6, pp. 1432-1438 (Jun. 1990).
- Y. Nakamura, et al., "Design of Bipolar Imaging Devices (BASIS): Analysis of Random Noise," IEEE Trans. on Electron Devices, vol. 39(6), pp. 1341-1349 (Jun. 1992).
- E. Fossum, "Active-pixel sensors challenge CCDs," Laser Focus World, vol. 29, pp. 83-87 (Jun. 1993).
- S. Mendis, et al., "A 128 x 128 CMOS Active Pixel Image Sensor for Highly Integrated Imaging Systems," Proc. of the 1993 IEEE International Electron Devices Meeting, pp. 583-586 (1993).
- S. Mendis, et al., "Progress in CMOS Active Pixel Image Sensors," Proc. SPIE, vol. 2172, pp. 19-29 (1994).
- S. Mendis, et al., "CMOS Active Pixel Image Sensor," IEEE Trans. on Electron Devices, vol. 41, No. 3, pp. 452-453 (Mar. 1994).
- T. Kimugass, et al., "An Electronic Variable-Shutter System in Video Camera Use," IEEE Transactions on Consumer Electronics, vol. CE-33, No. 3, pp. 249-255 (1987).
- S. Mendis, et al., "CMOS Active Pixel Image Sensor," Citation Unknown, pp. 1-7 (Jul. 1993).

* cited by examiner

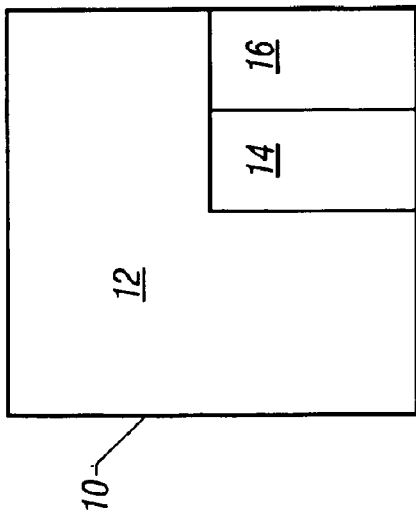

FIG. 1

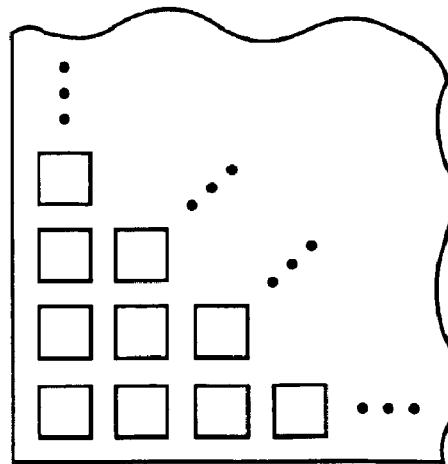

FIG. 2

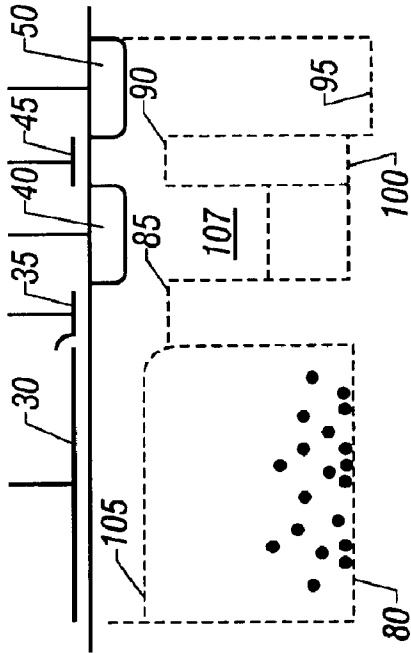

FIG. 4

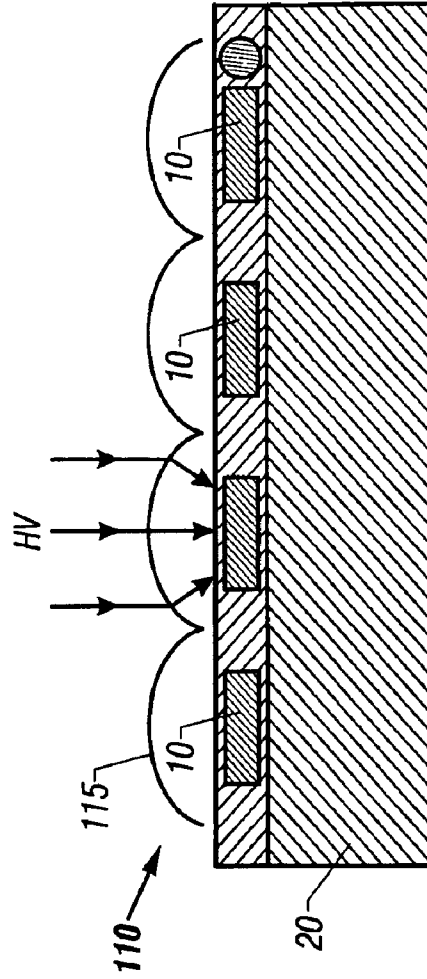

FIG. 5

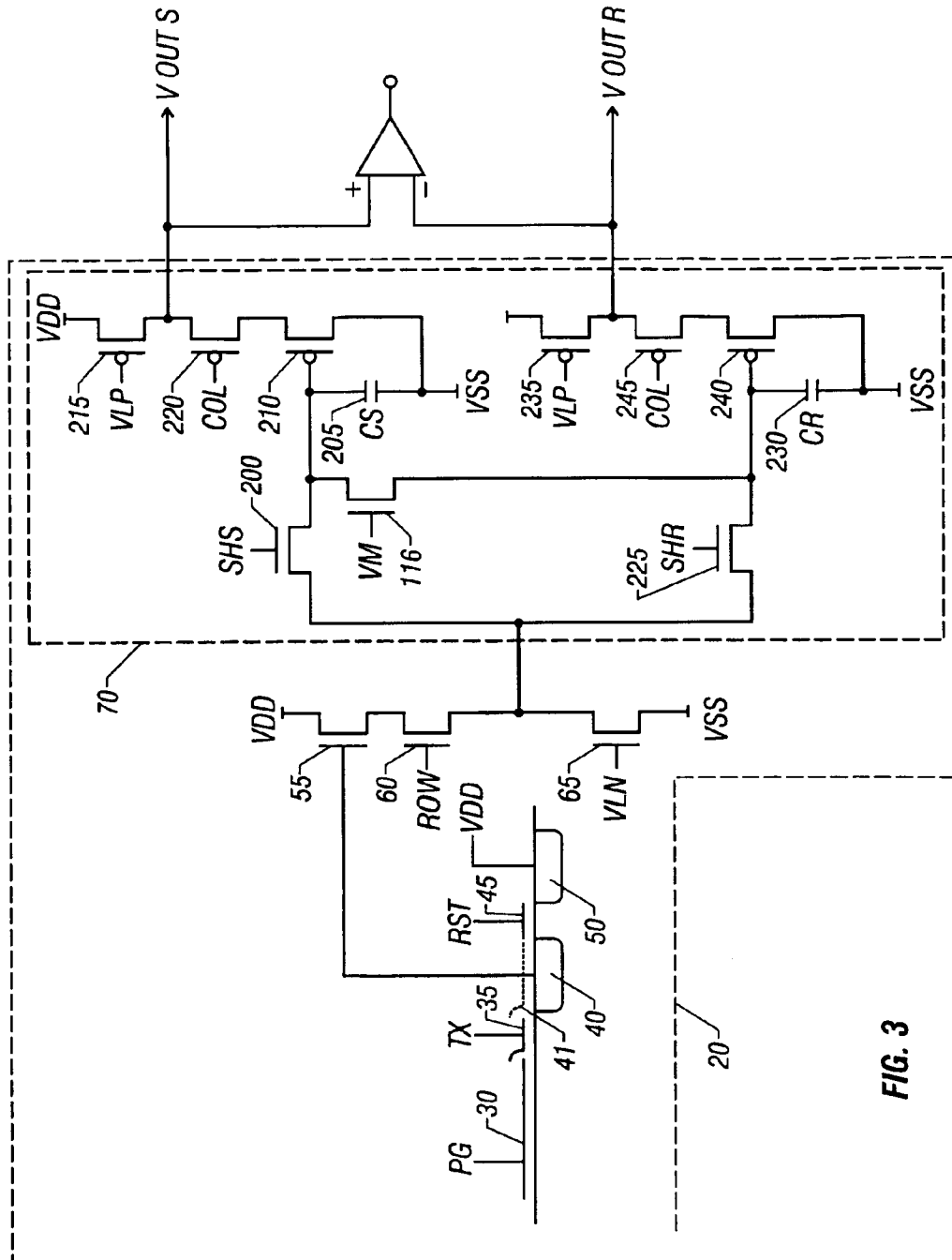

FIG. 3

1

METHOD OF ACQUIRING AN IMAGE FROM AN OPTICAL STRUCTURE HAVING PIXELS WITH DEDICATED READOUT CIRCUITS

CROSS-REFERENCE TO RELATED APPLICATIONS

This application is a divisional of U.S. application Ser. No. 10/388,250, filed on Mar. 12, 2003 now U.S. Pat. No. 6,744,068, which is a divisional of U.S. application Ser. No. 09/604,846 filed on Jun. 27, 2000 now U.S. Pat. No. 6,555,842 and U.S. application Ser. No. 08/558,521 filed Nov. 16, 1995, now U.S. Pat. No. 6,101,232 issued Aug. 8, 2000, and U.S. application Ser. No. 08/188,032 filed Jan. 28, 1994, now U.S. Pat. No. 5,471,515 issued Nov. 28, 1995.

ORIGIN OF THE INVENTION

The invention described herein was made in the performance of work under a NASA contract, and is subject to the provisions of Public Law 96-517 (35 USC 202) in which the Contractor has elected to retain title.

BACKGROUND OF THE INVENTION

1. Technical Field

The invention is related to semiconductor imaging devices and in particular to a silicon imaging device which can be fabricated using a standard CMOS process.

2. Background Art

There are a number of types of semiconductor imagers, including charge coupled devices, photodiode arrays, charge injection devices and hybrid focal plane arrays. Charge coupled devices enjoy a number of advantages because they are an incumbent technology, they are capable of large formats and very small pixel size and they facilitate noiseless charge domain processing techniques (such as binning and time delay integration). However, charge coupled device imagers suffer from a number of disadvantages. For example, they exhibit destructive signal read-out and their signal fidelity decreases as the charge transfer efficiency raised to the power of the number of stages, so that they must have a nearly perfect charge transfer efficiency. They are particularly susceptible to radiation damage, they require good light shielding to avoid smear and they have high power dissipation for large arrays.

In order to ameliorate the charge transfer inefficiency problem, charge coupled device (CCD) imagers are fabricated with a specialized COD semiconductor fabrication process to maximize their charge transfer efficiency. The difficulty is that the standard CCD process is incompatible with complementary metal oxide semiconductor (CMOS) processing, while the image signal processing electronics required for the imager are best fabricated in CMOS. Accordingly, it is impractical to integrate on-chip signal processing electronics in a CCD imager. Thus, the signal processing electronics is off-chip. Typically, each column of CCD pixels is transferred to a corresponding cell of a serial output register, whose output is amplified by a single on-chip amplifier (e.g., a source follower transistor) before being processed in off-chip signal processing electronics. As a result, the read-out frame rate is limited by the rate at which the on-chip amplifier can handle charge packets divided by the number of pixels in the imager.

The other types of imager devices have problems as well. Photodiode arrays exhibit high noise due to so-called kTC noise which makes it impossible to reset a diode or capacitor

2

node to the same initial voltage at the beginning of each integration period. Photodiode arrays also suffer from lag. Charge injection devices also suffer from high noise, but enjoy the advantage of non-destructive readout over charge coupled devices.

Hybrid focal plane arrays exhibit less noise but are prohibitively expensive for many applications and have relatively small array sizes (e.g., 512-by-512 pixels).

What is needed is an imager device which has the low kTC noise level of a CCD without suffering from the destructive readout tendencies of a CCD.

SUMMARY OF THE DISCLOSURE

The invention is embodied in an imaging device formed as a monolithic complementary metal oxide semiconductor integrated circuit in an industry standard complementary metal oxide semiconductor process, the integrated circuit including a focal plane array of pixel cells, each one of the cells including a photogate overlying the substrate for accumulating photo-generated charge in an underlying portion of the substrate, a readout circuit including at least an output field effect transistor formed in the substrate, and a charge coupled device section formed on the substrate adjacent the photogate having a sensing node connected to the output transistor and at least one charge coupled device stage for transferring charge from the underlying portion of the substrate to the sensing node.

In a preferred embodiment, the sensing node of the charge coupled device stage includes a floating diffusion, and the charge coupled device stage includes a transfer gate overlying the substrate between the floating diffusion and the photogate. This preferred embodiment can further include apparatus for periodically resetting a potential of the sensing node to a predetermined potential, including a drain diffusion connected to a drain bias voltage and a reset gate between the floating diffusion and the drain diffusion, the reset gate connected to a reset control signal.

Preferably, the output transistor is a field effect source follower transistor, the floating diffusion being connected to a gate of the source follower transistor. Preferably, the readout circuit further includes a double correlated sampling circuit having an input node connected to the output transistor. In the preferred implementation, the double correlated sampling circuit samples the floating diffusion immediately after it has been reset at one capacitor and then, later, at the end of the integration period at another capacitor. The difference between the two capacitors is the signal output. In accordance with a further refinement, this difference is corrected for fixed pattern noise by subtracting from it another difference sensed between the two capacitors while they are temporarily shorted.

BRIEF DESCRIPTION OF THE DRAWINGS

FIG. 1 is a diagram illustrating the architecture of an individual focal plane cell of the invention.

FIG. 2 is a plan view of an integrated circuit constituting a focal plane array of cells of the type illustrated in FIG. 1. FIG. 3 is a schematic diagram of the cell of FIG. 1.

FIG. 4 is a graph of the surface potential in the the charge transfer section of the cell of FIG. 3

FIG. 5 is a cross-sectional view of an alternative embodiment of the focal plane array of FIG. 2 including a micro-lens layer.

DETAILED DESCRIPTION OF THE PREFERRED EMBODIMENTS

FIG. 1 is a simplified block diagram of one pixel cell 10 of a focal plane array of many such cells formed in an inte-

grated circuit. Each cell **10** includes a photogate **12**, a charge transfer section **14** adjacent the photogate **12** and a readout circuit **16** adjacent the charge transfer section **14**. FIG. 2 shows a focal plane array of many cells **10** formed on a silicon substrate **20**. FIG. 3 is a simplified schematic diagram of a cell **10**. Referring to FIG. 3, the photogate **12** consists of a relative large photogate electrode **30** overlying the substrate **20**. The charge transfer section **14** consists of a transfer gate electrode **35** adjacent the photogate electrode **30**, a floating diffusion **40**, a reset electrode **45** and a drain diffusion **50**. The readout circuit **16** consists of a source follower field effect transistor (FET) **55**, a row select FET **60**, a load FET **65** and a correlated double sampling circuit **70**.

Referring to the surface potential diagram of FIG. 4, the photogate electrode **30** is held by a photogate signal PG at a positive voltage to form a potential well **80** in the substrate **20** in which photo-generated charge is accumulated during an integration period. The transfer gate electrode **35** is initially held at a less positive voltage by a transfer gate signal TX to form a potential barrier **85** adjacent the potential well **80**. The floating diffusion **40** is connected to the gate of the source follower FET **55** whose drain is connected to a drain supply voltage VDD. The reset electrode **45** is initially held by a reset signal RST at a voltage corresponding to the voltage on the transfer gate **30** to form a potential barrier **90** thereunder. The drain supply voltage VDD connected to the drain diffusion **50** creates a constant potential well **95** underneath the drain diffusion **50**.

During the integration period, electrons accumulate in the potential well **80** in proportion to photon flux incident on the substrate **20** beneath the photogate electrode **30**. At the end of the integration period, the surface potential beneath the floating diffusion **40** is quickly reset to a potential level **100** slightly above the potential well **95**. This is accomplished by the reset signal RST temporarily increasing to a higher positive voltage to temporarily remove the potential barrier **90** and provide a downward potential staircase from the transfer gate potential barrier **85** to the drain diffusion potential well **95**, as indicated in the drawing of FIG. 4. After the reset gate **45** is returned to its initial potential (restoring the potential barrier **90**), the readout circuit **70** briefly samples the potential of the floating diffusion **40**, and then the cell **10** is ready to transfer the photo-generated charge from beneath the photogate electrode **30**. For this purpose, the photogate signal PG decreases to a less positive voltage to form a potential barrier **105** beneath the photogate electrode **30** and thereby provide a downward staircase surface potential from the photogate electrode **30** to the potential well **100** beneath the floating diffusion **40**. This transfers all of the charge from beneath the photogate electrode **30** to the floating diffusion **40**, changing the potential of the floating diffusion **40** from the level (**100**) at which it was previously reset to a new level **107** indicative of the amount of charge accumulated during the integration period. This new potential of the floating diffusion **40** is sensed at the source of the source follower FET **55**. However, before the readout circuit **70** samples the source of the source follower FET **55**, the photogate signal PG returns to its initial (more positive) voltage. The entire process is repeated for the next integration period.

The readout circuit **70** consists of a signal sample and hold (S/H) circuit including an S/H FET **200** and a signal store capacitor **205** connected through the S/H FET **200** and through the row select FET **60** to the source of the source follower FET **55**. The other side of the capacitor **205** is connected to a source bias voltage VSS. The one side of the

capacitor **205** is also connected to the gate of an output FET **210**. The drain of the output FET is connected through a column select FET **220** to a signal sample output node VOUTS and through a load FET **215** to the drain voltage VDD. A signal called "signal sample and hold" (SHS) briefly turns on the S/H FET **200** after the charge accumulated beneath the photogate electrode **30** has been transferred to the floating diffusion **40**, so that the capacitor **205** stores the source voltage of the source follower FET **55** indicating the amount of charge previously accumulated beneath the photogate electrode **30**.

The readout circuit **70** also consists of a reset sample and hold (S/H) circuit including an S/H FET **225** and a signal store capacitor **230** connected through the S/H FET **225** and through the row select FET **60** to the source of the source follower FET **55**. The other side of the capacitor **230** is connected to the source bias voltage VSS. The one side of the capacitor **230** is also connected to the gate of an output FET **240**. The drain of the output FET **240** is connected through a column select FET **245** to a reset sample output node VOUTR and through a load FET **235** to the drain voltage VDD. A signal called "reset sample and hold" (SHR) briefly turns on the S/H FET **225** immediately after the reset signal RST has caused the resetting of the potential of the floating diffusion **40**, so that the capacitor **230** stores the voltage at which the floating diffusion has been reset to.

The readout circuit provides correlated double sampling of the potential of the floating diffusion, in that the charge integrated beneath the photogate **12** each integration period is obtained at the end of each integration period from the difference between the voltages at the output nodes VOUTS and VOUTR of the readout circuit **70**. This eliminates the effects of kTC noise because the difference between VOUTS and VOUTR is independent of any variation in the reset voltage RST, a significant advantage.

Referring to FIG. 5, a transparent refractive microlens layer **110** may be deposited over the top of the focal plane array of FIG. 2. The microlens layer **110** consists of spherical portions **115** centered over each of the cells **10** and contoured so as to focus light toward the center of each photogate **12**. This has the advantage of using light that would otherwise fall outside of the optically active region of the photogate **12**. For example, at least some of the light ordinarily incident on either the charge transfer section **14** or the readout circuit **16** (FIG. 1) would be sensed in the photogate area with the addition of the microlens layer **110**.

Preferably, the focal plane array corresponding to FIGS. 1-4 is implemented in CMOS silicon using an industry standard CMOS fabrication process. Preferably, each of the FETs is a MOSFET, the FETs **55**, **60**, **65**, **200** and **225** being n-channel devices and the FETs **210**, **220**, **225**, **230**, **240**, **245** being p-channel devices. The n-channel MOSFETs and the CCD channel underlying the gate electrodes **30**, **35**, **45** and the diffusions **40** and **50** may be located in a p-well while the remaining (p-channel) devices are located outside of the p-well. The gate voltage VLP applied to the gates of the p-channel load FETs **215** and **235** is a constant voltage on the order of +2.5 volts. The gate voltage VLN applied to the n-channel load FET **65** is a constant voltage on the order of +1.5 volts.

Since the charge transfer section **14** involves only a single CCD stage between the photogate **12** and the floating diffusion **40** in the specific embodiment of FIG. 3, there is no loss due to charge transfer inefficiency and therefore there is no need to fabricate the device with a special CCD process. As a result, the readout circuit **70** as well as the

5

output circuitry of the FETs **55**, **60** and **65** can be readily implemented as standard CMOS circuits, making them extremely inexpensive. However, any suitable charge coupled device architecture may be employed to implement the charge transfer section **14**, including a CCD having more than one stage. For example, two or three stages may be useful for buffering two or three integration periods.

Other implementations of the concept of the invention may be readily constructed by the skilled worker in light of the foregoing disclosure. For example, the floating diffusion **40** may instead be a floating gate electrode. The signal and reset sample and hold circuits of the readout circuit **70** may be any suitable sample and hold circuits. Moreover, shielding of the type well-known in the art may be employed defining an aperture surrounding the photogate **12**. Also, the invention may be implemented as a buried channel device.

Another feature of the invention which is useful for eliminating fixed pattern noise due to variations in FET threshold voltage across the substrate **20** is a shorting FET **116** across the sampling capacitors **205**, **235**. After the accumulated charge has been measured as the potential difference between the two output nodes VOUTS and VOUTR, a shorting signal VM is temporarily applied to the gate of the shorting FET **116** and the VOUTS-to-VOUTR difference is measured again. This latter difference is a measure of the disparity between the threshold voltages of the output FETs **210**, **240**, and may be referred to as the fixed pattern difference. The fixed pattern difference is subtracted from the difference between VOUTS and VOUTR measured at the end of the integration period, to remove fixed pattern noise.

As previously mentioned herein, a floating gate may be employed instead of the floating diffusion **40**. Such a floating gate is indicated schematically in FIG. **3** by a simplified dashed line floating gate electrode **41**.

Preferably, the invention is fabricated using an industry standard CMOS process, so that all of the dopant concen-

6

trations of the n-channel and p-channel devices and of the various diffusions are in accordance with such a process. In one implementation, the area of the L-shaped photogate **12** (i.e., the photogate electrode **30**) was about 100 square microns; the transfer gate electrode **35** and the reset gate electrode were each about 1.5 microns by about 6 microns; the photogate signal PG was varied between about +5 volts (its more positive voltage) and about 0 volts (its less positive voltage); the transfer gate signal TX was about +2.5 volts; the reset signal RST was varied between about +5 volts (its more positive voltage) and about +2.5 volts (its less positive voltage); the drain diffusion **50** was held at about +5 volts.

While the invention has been described in detail by specific reference to preferred embodiments, it is understood that variations and modifications may be made without departing from the true spirit and scope of the invention.

What is claimed is:

1. A method of acquiring an image, comprising:
 - defining a plurality of pixel areas, each said pixel area covering a specific optical area of a charge accumulating substrate,
 - configuring each of said plurality of pixel areas as a portion of said substrate,
 - providing a photogate controlling a characteristic of said charge accumulating substrate;
 - sensing charge in said charge accumulating substrate; and
 - associating a readout circuit provided with sensing nodes of each of said pixel areas, in a way that each said pixel area includes a dedicated readout circuit which is individually associated with each said pixel area.
2. A method as in claim 1, wherein a circuitry portion of said pixel area includes circuitry therein, and further comprising a lens system, covering at least said circuitry portion, and refracting impinging radiation to an area of said photogate.

* * * * *