



US007053929B2

(12) **United States Patent**  
**Yadid-Pecht et al.**

(10) **Patent No.:** **US 7,053,929 B2**  
(45) **Date of Patent:** **May 30, 2006**

- (54) **CENTER OF MASS DETECTION VIA AN ACTIVE PIXEL SENSOR**
- (75) Inventors: **Orly Yadid-Pecht**, Haifa (IL); **Brad Minch**, Pasadena, CA (US); **Bedabrara Pain**, Los Angeles, CA (US); **Eric Fossum**, La Crescenta, CA (US)
- (73) Assignee: **The United States of America as represented by the Administrator of the National Aeronautics and Space Administration**, Washington, DC (US)
- (\* ) Notice: Subject to any disclaimer, the term of this patent is extended or adjusted under 35 U.S.C. 154(b) by 345 days.
- (21) Appl. No.: **10/289,501**
- (22) Filed: **Nov. 5, 2002**
- (65) **Prior Publication Data**  
US 2003/0063817 A1 Apr. 3, 2003
- Related U.S. Application Data**
- (62) Division of application No. 09/114,347, filed on Jul. 13, 1998, now Pat. No. 6,476,860.
- (60) Provisional application No. 60/052,400, filed on Jul. 14, 1997.
- (51) **Int. Cl.**  
**H04N 5/225** (2006.01)
- (52) **U.S. Cl.** ..... **348/172; 348/302; 382/288**
- (58) **Field of Classification Search** ..... **348/169, 348/170, 171, 172, 302; 382/288; H04N 5/225**  
See application file for complete search history.

- (56) **References Cited**
- U.S. PATENT DOCUMENTS
- 5,055,926 A \* 10/1991 Christensen et al. .... 348/172
- 5,631,697 A \* 5/1997 Nishimura et al. .... 348/172
- OTHER PUBLICATIONS
- M. Tartagni and P. Perona; Computing centroids in current-mode technique; Aug. 5, 1993; IEE, Electronics Letters Online No. 19931188.
- \* cited by examiner
- Primary Examiner*—Young Lee
- (74) *Attorney, Agent, or Firm*—Fish & Richardson, PC

(57) **ABSTRACT**

An imaging system for identifying the location of the center of mass ("COM") in an image. In one aspect, an imaging system includes a plurality of photosensitive elements arranged in a matrix. A center of mass circuit coupled to the photosensitive elements includes a resistive network and a normalization circuit including at least one bipolar transistor. The center of mass circuit identifies a center of mass location in the matrix and includes: a row circuit, where the row circuit identifies a center of mass row value in each row of the matrix and identifies a row intensity for each row; a horizontal circuit, where the horizontal circuit identifies a center of mass horizontal value; and a vertical circuit, where the vertical circuit identifies a center of mass vertical value. The horizontal and vertical center of mass values indicate the coordinates of the center of mass location for the image.

**22 Claims, 4 Drawing Sheets**

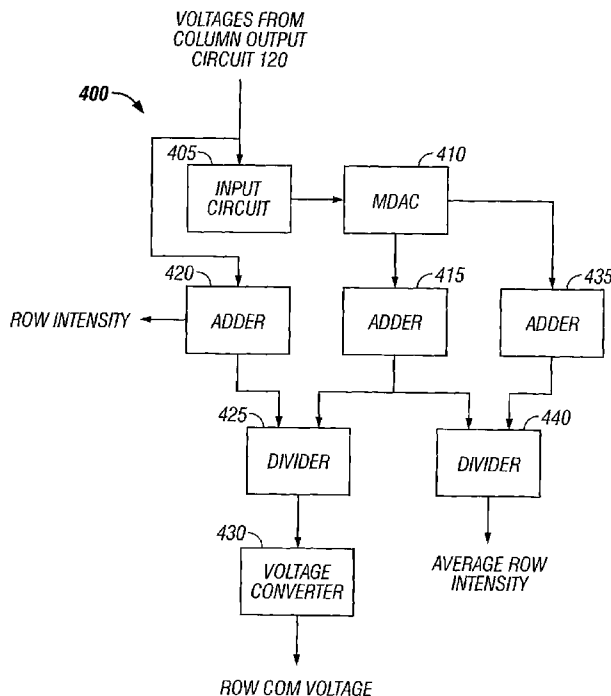

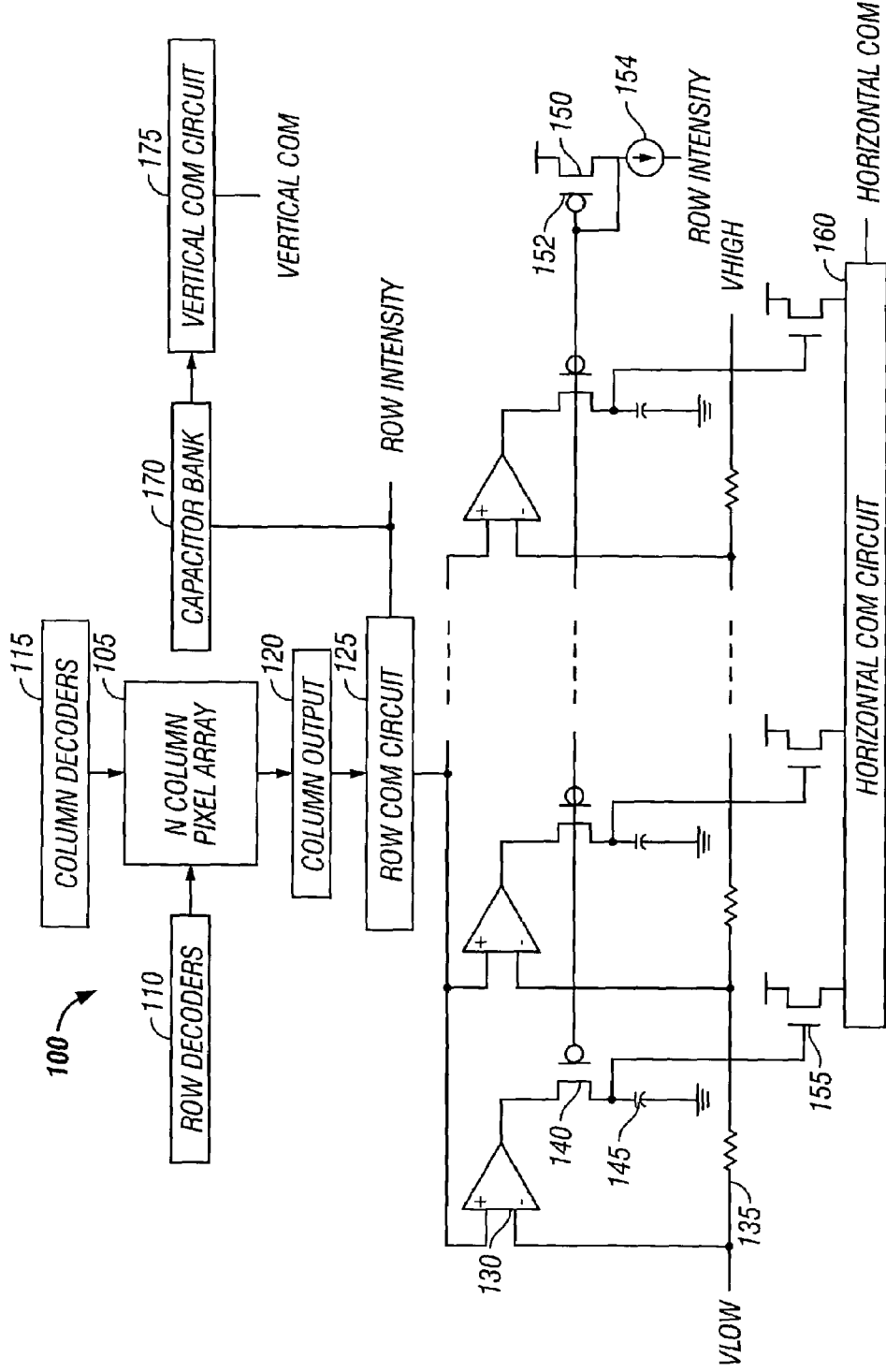

FIG. 1

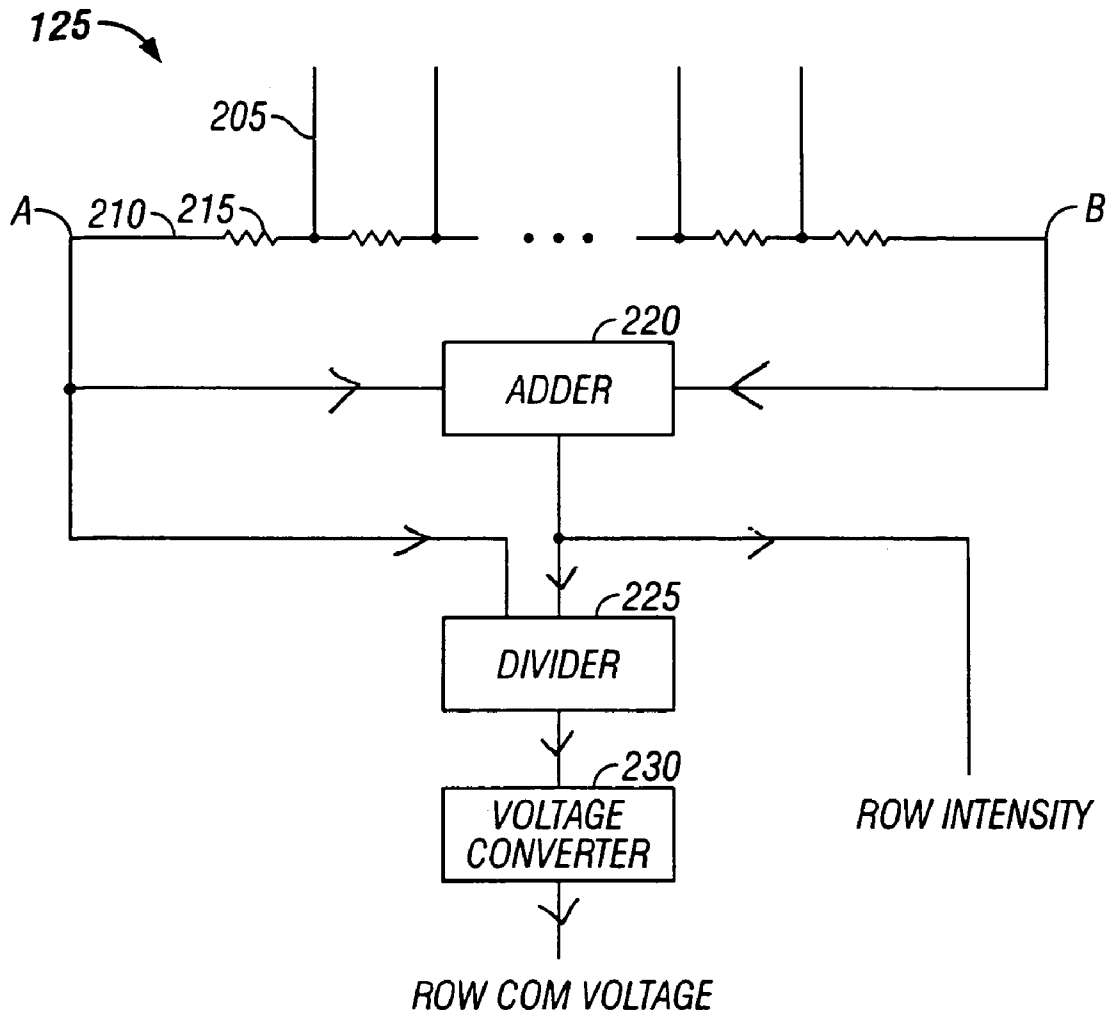

FIG. 2

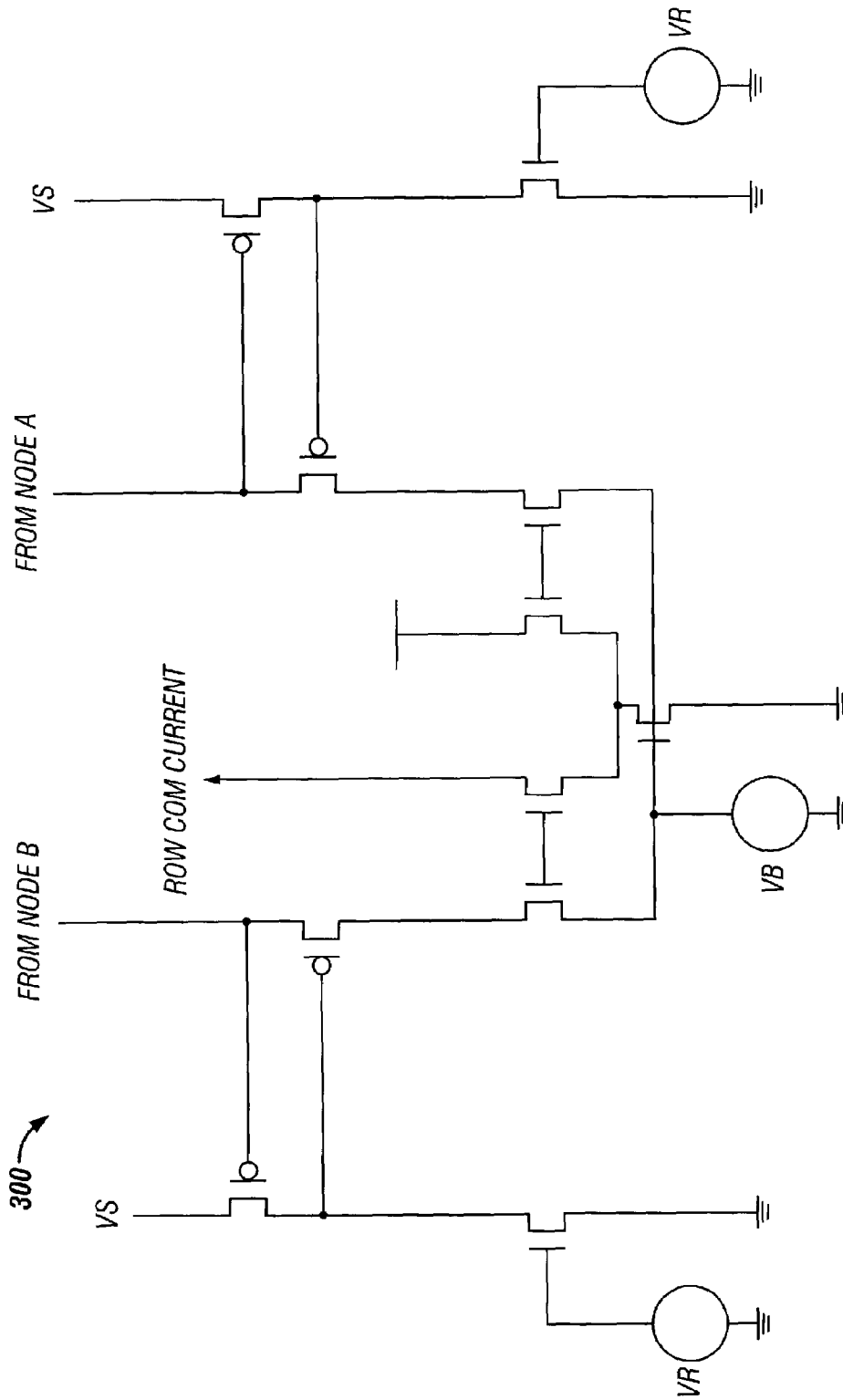

FIG. 3

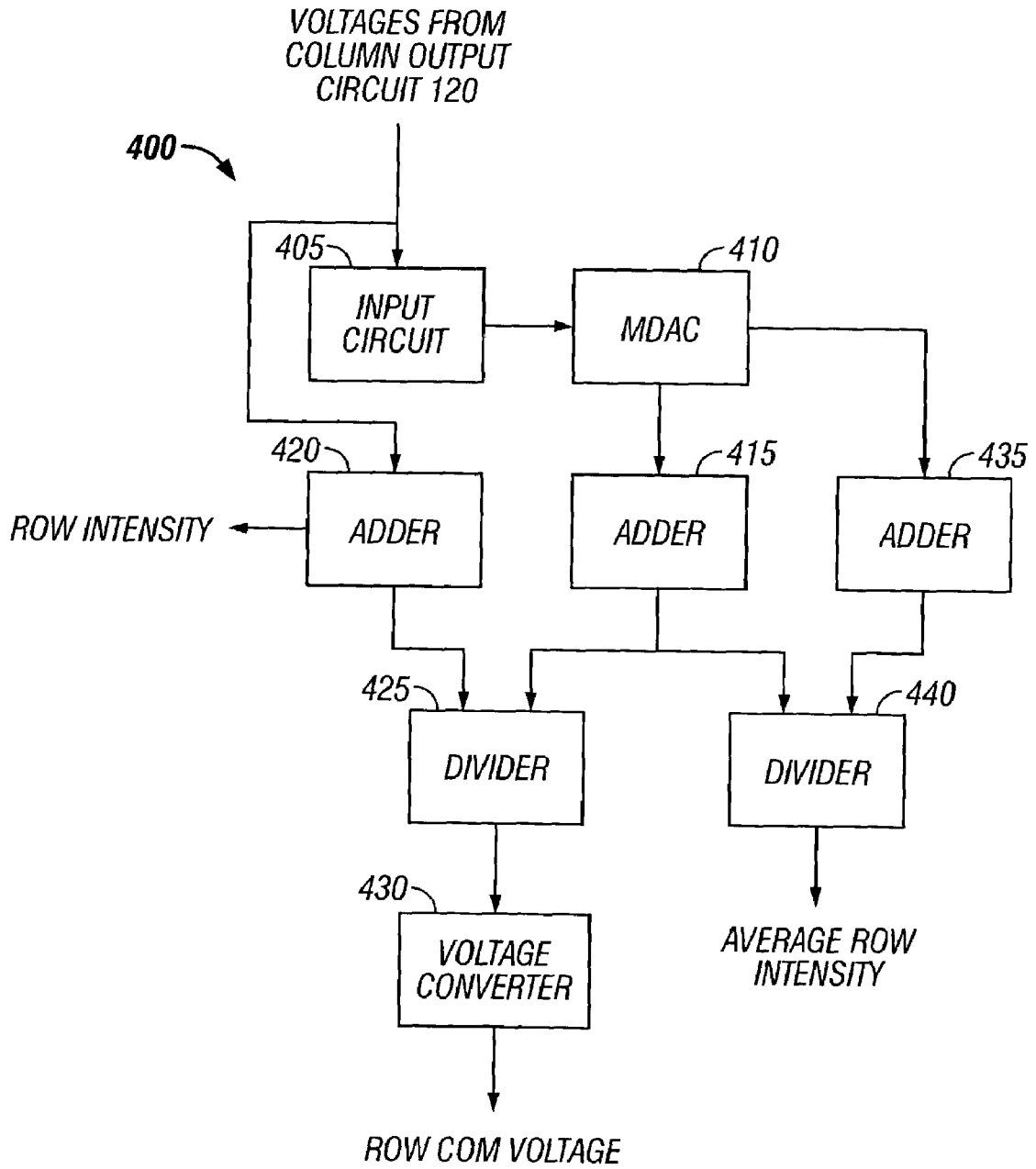

FIG. 4

1

## CENTER OF MASS DETECTION VIA AN ACTIVE PIXEL SENSOR

### CROSS-REFERENCE TO RELATED APPLICATIONS

This application is a divisional application of and claims priority to U.S. application Ser. No. 09/114,347, filed on Jul. 13, 1998 now U.S. Pat. No. 6,476,860, which claims the benefit of U.S. Provisional Application No. 60/052,400, filed on Jul. 14, 1997, which is incorporated herein by reference.

### STATEMENT AS TO FEDERALLY SPONSORED RESEARCH

The invention described herein was made in the performance of work under a NASA contract, and is subject to the provisions of Public Law 96-517 (35 U.S.C. 202) in which the Contractor has elected to retain title.

### TECHNICAL FIELD

The present disclosure relates to image analysis, and more particularly to identifying the center of mass in an image.

### BACKGROUND

Tracking of an item of interest in the image is desirable in various imaging applications. For example, in controlling the position of a camera for star tracking, the camera may adjust to center on a star. Similarly, it may be desirable for a camera for video conferencing to track a moving object such as a speaker. In order to track the item, an imaging system typically analyzes a captured frame of image data to determine the location of the center of mass ("COM") or centroid of the image. In an image, the COM is the location in the image which corresponds to the average light intensity, weighted by location. The camera then typically tracks that COM location.

In imaging systems which use an active pixel sensor ("APS") for image capture, the APS is typically fabricated with a CMOS process. However, conventional CMOS sensor imaging systems which identify the COM are typically limited in their imaging capability.

In research by Shibata, capacitor scaling was used for identifying the COM in a relatively small number of inputs, such as 25 inputs. However, capacitor scaling for a large number of inputs, such as in a large image, using this technique is not very practical.

In research by Deweerth and Mead, a 1D photoreceptor array which computed the COM in an analog circuit was introduced. Deweerth proposed a 2D extension of this array in which the receptors were alternated spatially so that the currents from adjacent receptors were added to opposing axes. The resolution was limited in the 2D case to be half of that of the 1D case. In addition, the circuitry for calculating the COM resided in each pixel and contributed to both axes. Thus, the fill factor was lower than in the 1D case.

Furthermore, the circuit only tracked the COM, regular readout imaging was not available through the same imager.

### SUMMARY

The present disclosure describes apparatus and techniques for identifying the location of the center of mass ("COM") in an image. In one aspect, an imaging system includes a plurality of photosensitive elements arranged in a matrix of

2

M columns and N rows, where  $M > 1$  and  $N > 1$ ; a center of mass circuit coupled to the photosensitive elements, including a resistive network and a normalization circuit including at least one bipolar transistor. The center of mass circuit identifies a center of mass location in the matrix and includes: a row circuit, where the row circuit identifies a center of mass row value in each row of the matrix and identifies a row intensity for each row; a horizontal circuit, where the horizontal circuit identifies a center of mass horizontal value relative to the matrix based upon the center of mass row values, such that the center of mass horizontal value indicates the horizontal coordinate of the center of mass location; and a vertical circuit, where the vertical circuit identifies a center of mass vertical value relative to the matrix based upon the row intensities, such that the center of mass vertical value indicates the vertical coordinate of the center of mass location.

An advantage of the techniques described herein is that the circuitry for identifying the COM is provided on the periphery of the imager so that regular imaging is possible without degradation from the COM circuitry. Also, the COM may be identified without reading out the entire frame of image data.

### BRIEF DESCRIPTION OF THE DRAWINGS

FIG. 1 is a diagram of an architecture of an imaging system according to the present disclosure.

FIG. 2 is a block diagram of a center of mass circuit according to the present disclosure.

FIG. 3 is a diagram of an implementation of a center of mass circuit.

FIG. 4 is a block diagram of a digital center of mass circuit.

### DETAILED DESCRIPTION

The center of mass ("COM") in an image may be described as the sum over all locations of light intensity at a location multiplied by the relative location. Thus, the COM is a weighted average of brightness, according to location. The present disclosure provides apparatus and techniques for identifying the COM for an image as a whole by calculating a row COM for each row in an image as well as the total brightness or intensity for each row. The results for the rows are superposed and a horizontal COM is calculated for that superposed value. The horizontal COM is the COM for the image as a whole in the horizontal direction. Similarly, a vertical COM of the row intensities is calculated. The vertical COM is the COM for the image as a whole in the vertical direction. The horizontal COM and the vertical COM indicate the COM for the image as a whole.

A COM circuit according to the present disclosure calculates the COM for a set of inputs by generating a voltage proportional to the COM location in the set of inputs. As noted above, three COM circuits may be included in an imaging system: a row COM circuit, a horizontal COM circuit, and a vertical COM circuit. The COM circuits may be positioned on the periphery of an imager, such as a matrix of photosensitive elements. By placing the COM circuits on the periphery, the image produced by the imager is not detrimentally affected by the COM circuits. Accordingly, the imaging system may operate in two modes: an imaging mode or a COM mode.

As shown in FIG. 1, one embodiment of an imaging system **100** includes a matrix **105** of photosensitive elements. Matrix **105** may be connected to and receive image

information from a lens (not shown). Imaging system **100** may be included in an image capturing device such as a camera. The matrix is preferably an active pixel sensor (“APS”) including APS photogates. The configuration and operation of an APS is described in U.S. Pat. No. 5,471,515 to Fossum et al., the disclosure of which is incorporated herein.

Matrix **105** is connected to a row decoder **110** and a column decoder **115** for controlling the elements of matrix **105**. Matrix **105** is also connected to a column output circuit **120**. An element in matrix **105** is indicated by the intersection of a row selected by row decoder **110** and a column selected by column decoder **115**. Row decoder **110** and column decoder **115** may select elements in a left to right and top to bottom order. For example, row decoder **110** first may select the uppermost row of matrix **105** and column decoder **115** may select the leftmost column of matrix **105**, indicating the element in the upper left corner of matrix **105**. Next, column decoder **115** may select the column to the right of the previously selected column, while row decoder **110** is held constant, and so on throughout matrix **105**.

Alternatively, row decoder **110** and column decoder **115** may indicate elements in a random access manner, i.e., not only by accessing an entire row at a time. By accessing elements in this way, a “window” within matrix **105** may be accessed. This window may be of any size or shape within matrix **105**. The window may be a square or any other shape, not necessarily contiguous, formed from a collection of elements indicated by row decoder **110** and column decoder **115**. In addition, the window may vary. For example, as a first pass, all the elements in matrix **105** may be accessed. In a second pass, a window of some subset of elements in matrix **105** may be accessed surrounding a point of interest in the image.

The indicated element sends an image signal to column output circuit **120**. This image signal represents the portion of the image captured by imaging system **100** corresponding to the indicated element of matrix **105**. Column output circuit **120** stores the image signals from each element in the selected row. When no more elements in the selected row are to be accessed, column output circuit **120** sends the signals to a row COM circuit **125**. Where matrix **105** is an APS, the photogate row voltages are converted to currents and sent to row COM circuit **125** by converter circuits (not shown). Alternatively, the row voltages may be converted into currents in row COM circuit **125**.

Row COM circuit **125** identifies the location of the COM for the selected row in matrix **105**. As shown in FIG. 2, row COM circuit **125** includes a plurality of current lines **205**. Each current line **205** supplies a current for each column in matrix **105** to a resistive network **210**, such as a resistor string **210**. Resistor string **210** includes a plurality of resistors **215** joined in series. Resistor string **210** may include one resistor **215** for each current line **205**. Each current line **205** is connected to resistor string **210** adjacent to a corresponding resistor **215**. Thus, current lines **205** and resistor string **210** form a multiple input current divider. In order for the current divider to function properly, the voltage potentials at node A and node B preferably maintain the same potential.

In an alternative implementation, resistor string **210** includes MOSFETs instead of resistors. The gate electrode of each MOSFET is connected to a common reference voltage. Each current line **205** is connected to a source and drain between corresponding MOSFETs. The resulting functionality is substantially equivalent to that of the simple resistor string **210** described above. Performance and cost effectiveness may improve, however.

All of the current supplied from column output circuit **120** through current lines **205** flows through resistor string **210** and is divided between node A and node B. Accordingly, the sum of the current at node A and at node B is equal to a current representing the total light intensity for the selected row. A summation circuit **220** adds the current at node A and the current at node B to calculate a row intensity current. The row intensity current is stored in a corresponding capacitor in a bank of capacitors **170** and also supplied to a current mirror **150**, shown in FIG. 1, as described below.

A divider circuit **225** divides the current at node A by the row intensity current to generate a row COM current indicating the row COM location. The row COM current varies from 0 to 1 and is proportional to the location of the COM in the selected row. For example, if the row COM current is 0.5, the COM is approximately in the center of the row. The row COM current may indicate a non-integer value. A voltage converter **230** converts the row COM current to a row COM voltage which is output by row COM circuit **125**.

An implementation of a conventional COM circuit is described by Tartagni and Perona in “Computing Centroids in Current-mode Technique” in *Electronics Letters*, Vol. 29, No. 21, pp. 1811–13, October 1993, the disclosure of which is herein incorporated by reference. However, Tartagni’s COM circuit provides a value which is normalized such that 0 is at the center of the resistor string. The present disclosure considers it desirable to have 0 correspond to the left edge of the source of inputs. Therefore, it is desirable to construct a variation of Tartagni’s COM circuit to produce a different normalization. In addition, Tartagni’s COM circuit operates in the subthreshold regime of the transistors. Transistors operating above the subthreshold level may have an improved performance speed and be generally more desirable. Accordingly, bipolar lateral or vertical transistors are preferred in an embodiment according to the present disclosure.

Accordingly, as shown in FIG. 3, in one implementation, a single circuit **300** for generating the row COM current may be implemented using transistors. This circuit **300** is a variation of the circuit described by Tartagni. To normalize the row COM current to a value starting from 0, the current from node A is divided by the sum of the current from node A and the current of node B, as described above. Tartagni, by contrast, divides the difference between the current from node B and the current from node A by the sum of the current from node A and the current from node B. The voltage potentials VS, VR, and VB are described in more detail by Tartagni.

Returning to FIG. 1, the row COM voltage for each row is sent to a bank of high-gain comparators **130**, such as differential operational amplifiers. Each comparator **130** includes additional connections, such as for power and ground, which are not shown. The row COM voltage is supplied to a positive input of each comparator **130**. Each comparator **130** is connected to a resistor series **135**. Resistor series **135** includes a number of resistors connected in series. The number of resistors in resistor series **135** may be the same as the number of columns in matrix **105**, in which case each comparator **130** has a corresponding resistor in resistor series **135**. A voltage differential from VLOW to VHIGH is connected to resistor series **135**, such that the resistors of resistor series **135** linearly interpolate the voltage difference. VLOW may be 0 and VHIGH may be the maximum row COM voltage.

A negative input of each comparator **130** is connected to resistor series **135** before the corresponding resistor in resistor series **135**. For example, as shown in FIG. 1, the

leftmost comparator **130** is connected to resistor series **135** before the leftmost resistor in resistor series **135**. Thus, the negative input of each comparator **130** receives an increasingly larger voltage, progressing from left to right in FIG. 1.

Comparator **130** rails to a high output voltage when the voltage at the positive input is greater than the voltage at the negative input. Conversely, comparator **130** rails to a low output voltage, such as ground, when the voltage at the negative input is greater than the voltage at the positive input. Comparators **130** may be strobe comparators, such that a high output is only generated during a strobe cycle. The output from each comparator **130** is supplied to a source of a PMOS transistor **140**. The drain of each transistor **140** is connected to a capacitor **145**. The gate electrode of each transistor **140** is supplied with a current based upon the row intensity current of the selected row from row COM circuit **125**.

A current mirror **150** is formed from a transistor **152** and a current source **154**. Current mirror **150** also receives as input a reference voltage at the source of transistor **152** and the row intensity current at the drain of transistor **152**. Current mirror **150** outputs a current proportional to the row intensity current to the gate electrode of each PMOS transistor **140**.

When a comparator **130** outputs a high output voltage, the corresponding PMOS transistor **140** is “on” and a current proportional to the current supplied to the gate electrode of the PMOS transistor **140** is output from the drain. Thus, the output current is in turn proportional to the row intensity current. When a comparator **130** outputs a low output voltage, the corresponding PMOS transistor **140** is “off” and no current flows from the drain.

The drain of each PMOS transistor **140** is connected to a corresponding capacitor **145**. Each capacitor **145** stores a charge from the current supplied from the corresponding PMOS transistor **140**. Each capacitor may accumulate charge as row COM circuit **125** outputs a row COM voltage for each row. Thus, for each row COM voltage, capacitors **145** connected to PMOS transistors **140** connected to comparators **130** where the row COM voltage exceeds the corresponding voltage from resistor series **135** accumulate charge. In effect, the bank of capacitors **145** “superpose” the results of calculating the row COM value for each row.

Capacitor **145** is also connected to the gate electrode of a corresponding row transistor **155**. The source of row transistor **155** is connected to a reference voltage. The drain of row transistor **155** is connected to a horizontal COM circuit **160**. Row transistors **155** serve as buffers between capacitors **145** and horizontal COM circuit **160**. Thus, horizontal COM circuit **160** receives input based upon the accumulated row COM voltages stored as charge in capacitors **145**.

Horizontal COM circuit **160** is constructed similarly to row COM circuit **125**. Horizontal COM circuit **160** converts the supplied voltages to currents and generates a horizontal COM voltage based on the accumulated voltages from each of the rows accessed in matrix **105**. The horizontal COM voltage indicates the relative horizontal location of the COM for the entire frame.

A charge based on the row intensity current for each row is stored in a corresponding capacitor in a bank of capacitors **170**, as described above. After each row has been accessed and a corresponding row intensity current has been generated, capacitor bank **170** stores a charge for each row. A corresponding voltage is input to a vertical COM circuit **175** for each row. Vertical COM circuit, similar to row COM circuit **125** and horizontal COM circuit **160**, converts the voltages to currents and generates a vertical COM voltage.

The vertical COM voltage indicates the relative vertical location of the COM for the entire frame.

The horizontal COM voltage and the vertical COM voltage together indicate the location of the COM for the frame as a whole. While the description above focuses on reading out each row and column of matrix **105**, as described above, a subset of the elements in matrix **105** may be selected to form a sub-sample or window. In such a case, a similar process is used with a smaller set of inputs to generate a local COM for that window.

FIG. 4 shows an alternative implementation implementing a COM circuit **400** including digital circuitry. For a digital row COM circuit, as described above, column output circuit **120**, shown in FIG. 1, outputs a plurality of voltages corresponding to elements in matrix **105** to COM circuit **400**. An input circuit **405** includes an analog to digital converter and converts the voltages to digital brightness values representing the light intensity for each column in the selected row. Input circuit **405** also generates digital position values representing the relative location of each column in the selected row, such as 1 for the leftmost column, 2 for the next column, and so on.

Input circuit **405** supplies the brightness values and the position values to a multiplying digital to analog converter (“MDAC”) **410**. MDAC **410** generates a weighted current for each column by multiplying the corresponding brightness value by the corresponding position value. A first summation circuit **415** sums the weighted currents. A second summation circuit **420** converts the input voltages to brightness currents and sums those currents to generate the row intensity current. A first divider circuit **425** divides the sum of the weighted currents by the row intensity current to generate a row COM current. A voltage converter **430** converts the row COM current to a row COM voltage.

A third summation circuit **435** receives position currents from MDAC **410** representing the position values. Summation circuit **435** sums the position currents. A second divider circuit **440** divides the sum of the weighted currents from summation circuit **415** by the sum of the position currents from summation circuit **435** to generate an average intensity current. The average intensity current is used to determine the horizontal COM value.

A digital horizontal COM circuit is similar to the row COM circuit **400** shown in FIG. 4. A row COM current for each row, supplied by the digital row COM circuit, is multiplied by a corresponding average intensity current. This product is then divided by the sum of the average intensities to generate the horizontal COM value.

A digital vertical COM circuit is also similar to the row COM circuit **400** shown in FIG. 4. A row address value for each row is multiplied by the corresponding row intensity value. This product is divided by the sum of the row intensities to generate the vertical COM value.

In another alternative implementation, each of the digital COM circuits is more substantially digital with conversions occurring at the input and output. As above, a set of voltages corresponding to each of the elements in the selected row is converted to digital brightness values. Position values and address values are also generated. Each of the mathematical operations described above is performed on the digital values. At the end of each process a digital COM value may be converted to an analog COM voltage. Alternatively, the digital COM value can be used as a digital value.

In an alternative implementation, a COM circuit implemented using capacitor scaling may be used. The structure and operation of such a COM circuit is described by Shibata et al. in “Advances in Neuron-MOS Applications”, ISSCC



Proc., pp. 304–05, 1996, the disclosure of which is incorporated herein. A capacitor scaling COM circuit is limited to small applications with a relatively small number of inputs, as noted above. Thus, a capacitor scaling COM circuit may be used when the imager is small or only small windows are to be accessed.

Alternatively, capacitor scaling COM circuits may be included in an imaging system as a supplemental system. When a window is selected which is within the input limitation of the capacitor scaling COM circuits, these COM circuits may be used. When a larger window is selected, the COM circuits described above and shown in FIGS. 1–3 may be used. Because the capacitor scaling COM circuits are smaller they may be faster and more power efficient. This alternation between the two types of COM circuits may provide improved performance.

Additional variations and implementations are apparent to those of ordinary skill in the art. For example, alternative combinations of analog and digital circuitry may be implemented. The present disclosure is not limited by the embodiments described above, but only by the scope of the following claims.

What is claimed is:

1. A method, comprising:
  - determining, for a plurality of pixels forming a matrix, values associated with those pixels, which values represent an additive string of values along a direction of the pixels forming the matrix, and where each value is additively larger than a previous value, and represents a summation of all values along said direction up to a point of said each value, said determining comprises determining a first string of values along a horizontal direction representing additively and overall brightness of rows of the matrix and a second string of values along a vertical direction additively representing an overall brightness of columns of the matrix of the matrix;
  - finding a center of mass of an image represented by said additive string of values, by finding a value among said string of values which represents a midpoint between a lowest of said values and a highest of said values, and identifying locations associated with said midpoints.
2. A method as in claim 1, further comprising normalizing said values to have the lowest of said values be substantially 0, and the highest of said values be substantially 1, and said finding a value comprises finding a value which is substantially 0.5 as said center of mass value, for each of vertical and horizontal directions.
3. A method as in claim 2, further comprising obtaining a matrix of values, and allowing random access selection of a smaller matrix within said matrix and finding a center of mass for said random access selection.
4. A method as in claim 3, further comprising determining a first center of mass value for a first smaller matrix at a first time, and determining a second center of mass value for a second smaller matrix at a second time.
5. A method as in claim 2, wherein said normalizing comprises dividing current from one node by an amount of current from a sum of said one node and another node.
6. A method as in claim 1, further comprising determining values of a plurality of pixels using a photosensor array, and locating a plurality of center of mass circuits on a periphery of the photosensor array.
7. A method as in claim 6, wherein said determining comprises using a string of resistors arranged as a resistive divider to find said string of values by finding values between adjacent resistors in the string of values.

8. A method as in claim 6, wherein said determining comprises using a string of transistors arranged as a resistive divider to form said values, by finding values between adjacent transistors.

9. A method as in claim 1, wherein said determining comprises determining brightness values for a string of pixels, and summing said brightness values to determine said additive string of values.

10. A method as in claim 9, wherein said brightness values are digital, and said summing comprises determining a sum of row intensities.

11. A method as in claim 1, wherein said determining uses an array of scaled capacitors.

12. A method as in claim 1, further comprising determining values from a plurality of pixels.

13. A method as in claim 12, wherein said determining comprises determining values from active pixel sensors.

14. A system comprising:  
 an array of photosensitive pixels,  
 a first center of mass circuit, determining first values from said array of photosensitive pixels in a row direction, said first values representing additively and overall brightness of rows of the array, where each value is additively larger than a previous value, and represents a summation of all rows in the array up to a point of said each first value;  
 a second center of mass circuit, determining second values from said array of photosensitive pixels in a column direction, said second values additively representing an overall brightness of columns of the array, where each value is additively larger than a previous value and represents a summation of all columns in the array up to the point of said each second value; and  
 a center of mass determining circuit, finding a center of mass of an image represented by said first and second values, by finding midpoints within each of said first and second values, and identifying locations associated with said midpoints.

15. A system as in claim 14, wherein said first and second center of mass circuits are physically located around the periphery of the array of photosensitive pixels.

16. A system as in claim 15, wherein said photosensitive pixels are active pixel sensor type pixels.

17. A system as in claim 14, wherein said center of mass determining circuit includes a normalizing circuit which normalizes said values to between 0 and 1, and said center of mass determining circuit finds a value which is substantially 0.5 as said midpoint.

18. A system as in claim 17, further comprising a random access selection part, which allows selecting any of a plurality of random groups of said array of photosensitive pixel, and finding center of masses of said random groups.

19. A system as in claim 18, wherein said random access selection part allows selection of discontinuous groups which do not intersect.

20. A system as in claim 14, wherein said first and second center of mass circuits each include resistive dividers which produce said values.

21. A system as in claim 10 wherein said first and second center of mass circuits include digital detectors which digitally add brightness values to produce said values.

22. A system as in claim 10, wherein said first and second center of mass circuits use an array of scaled capacitors.