

(12) **United States Patent**
Fossum

(10) **Patent No.:** **US 6,704,049 B1**
(45) **Date of Patent:** **Mar. 9, 2004**

(54) **INTERPOLATOR FOR A CMOS IMAGE SENSOR USING A DIGITAL REGISTER**

6,133,954 A * 10/2000 Jie et al. 348/308

OTHER PUBLICATIONS

(75) **Inventor:** **Eric R. Fossum**, La Crescenta, CA (US)

Robert B. Darling and Robert B. Pinter, System Issues in the Implementation of Sensory Neural Network Photodetector Arrays, IEEE Pacific Rim Conference Paper, May 9-10, 1991.*

(73) **Assignee:** **Micron Technology, Inc.**, Boise, ID (US)

* cited by examiner

(*) **Notice:** Subject to any disclaimer, the term of this patent is extended or adjusted under 35 U.S.C. 154(b) by 0 days.

Primary Examiner—Tuan Ho

(74) *Attorney, Agent, or Firm*—Dickstein Shapiro Morin & Oshinsky LLP

(21) **Appl. No.:** **09/028,961**

(57) **ABSTRACT**

(22) **Filed:** **Feb. 23, 1998**

An imager has first and second photosensitive sites and an interpolator located in a semiconductor substrate. The first photosensitive site is configured to receive light having a spectral component, and the second photosensitive site is configured to measure the level of the spectral component in light received by the second photosensitive site. The interpolator is configured to estimate the level of the spectral component in the light received by the first photosensitive site based on the measurement by the second photosensitive site.

(51) **Int. Cl.⁷** **H04N 5/335**

(52) **U.S. Cl.** **348/272; 348/308**

(58) **Field of Search** 348/272, 273, 348/280, 281, 282, 307, 308, 222.1, 223.1; 250/208.1, 226

(56) **References Cited**

U.S. PATENT DOCUMENTS

5,852,468 A * 12/1998 Okada 348/272

22 Claims, 6 Drawing Sheets

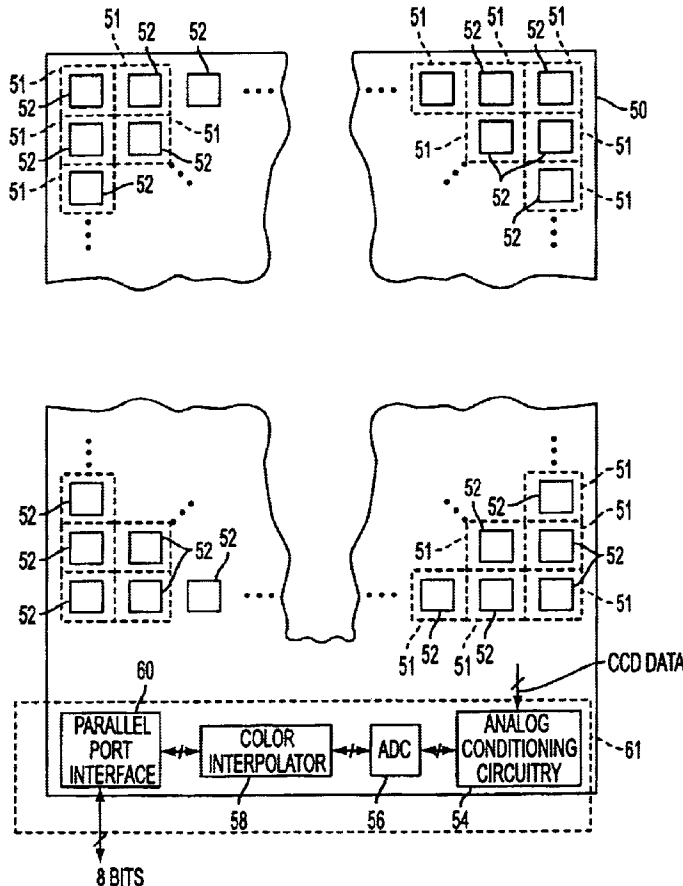

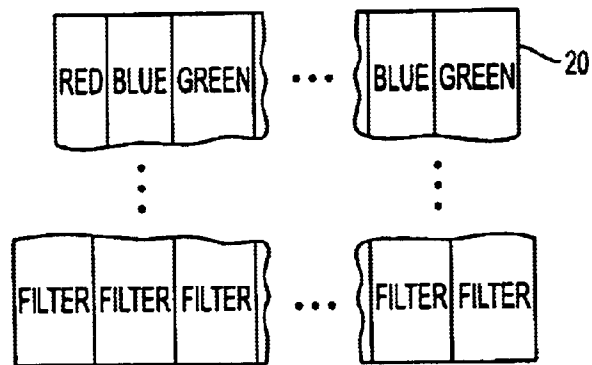
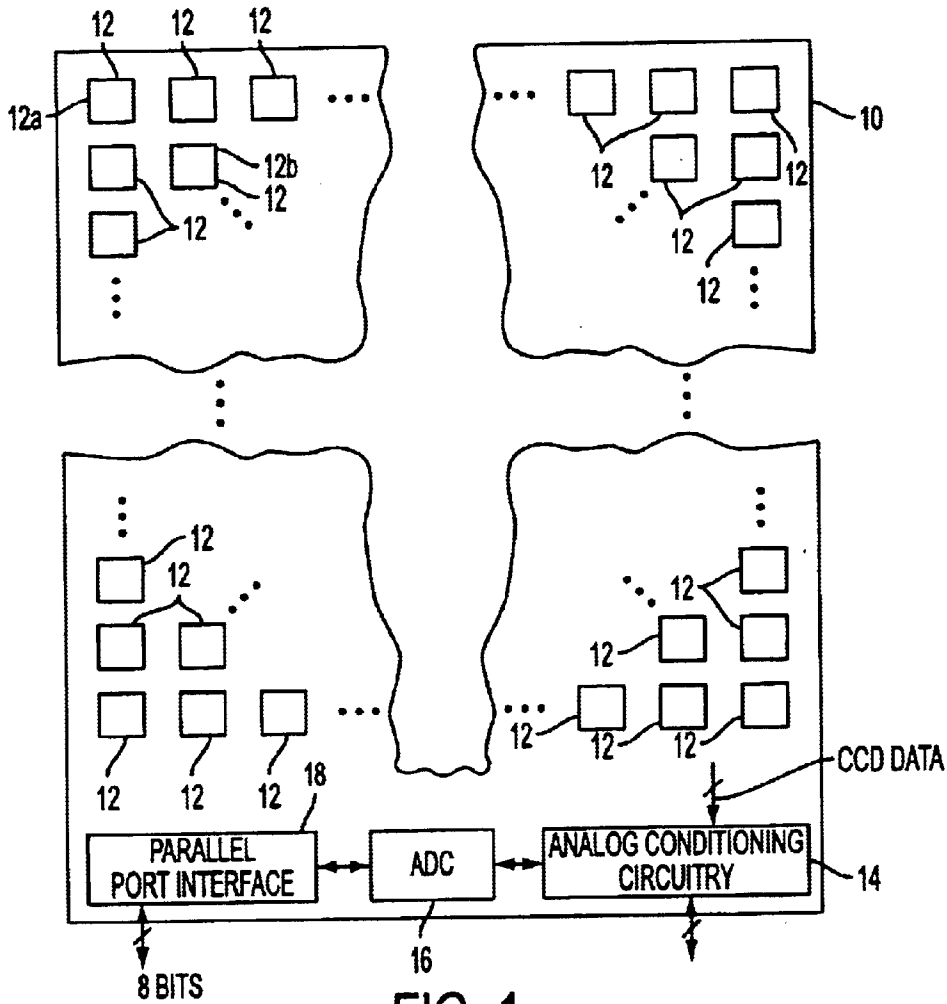

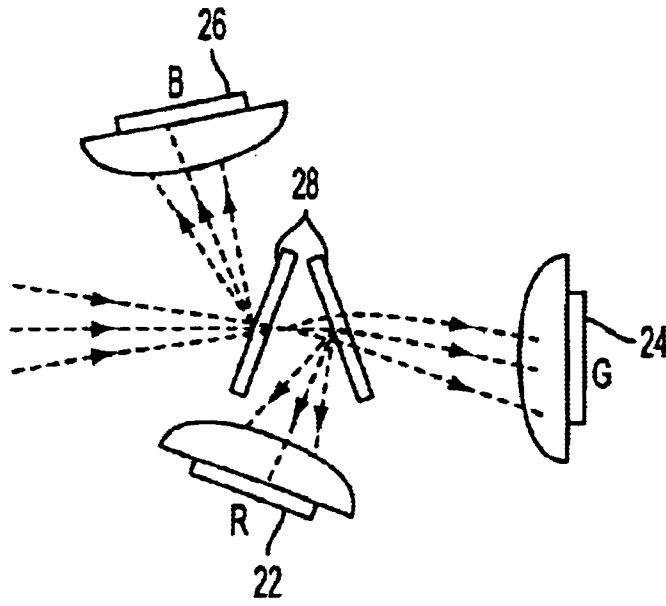

FIG. 3
(PRIOR ART)

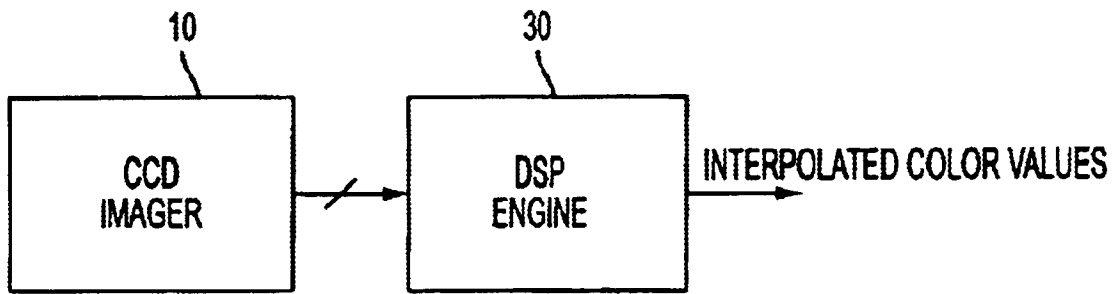

FIG. 4
(PRIOR ART)

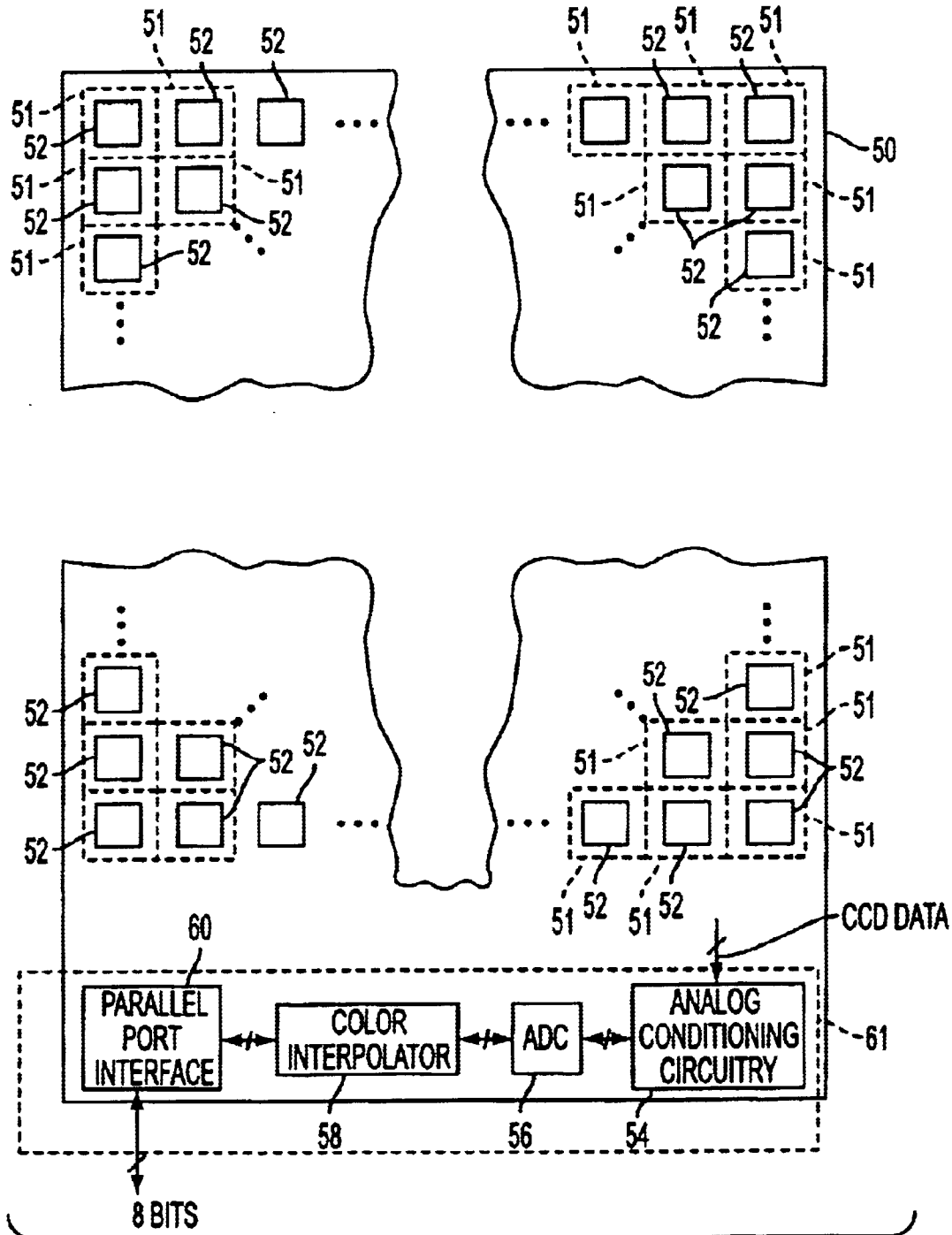

FIG. 5

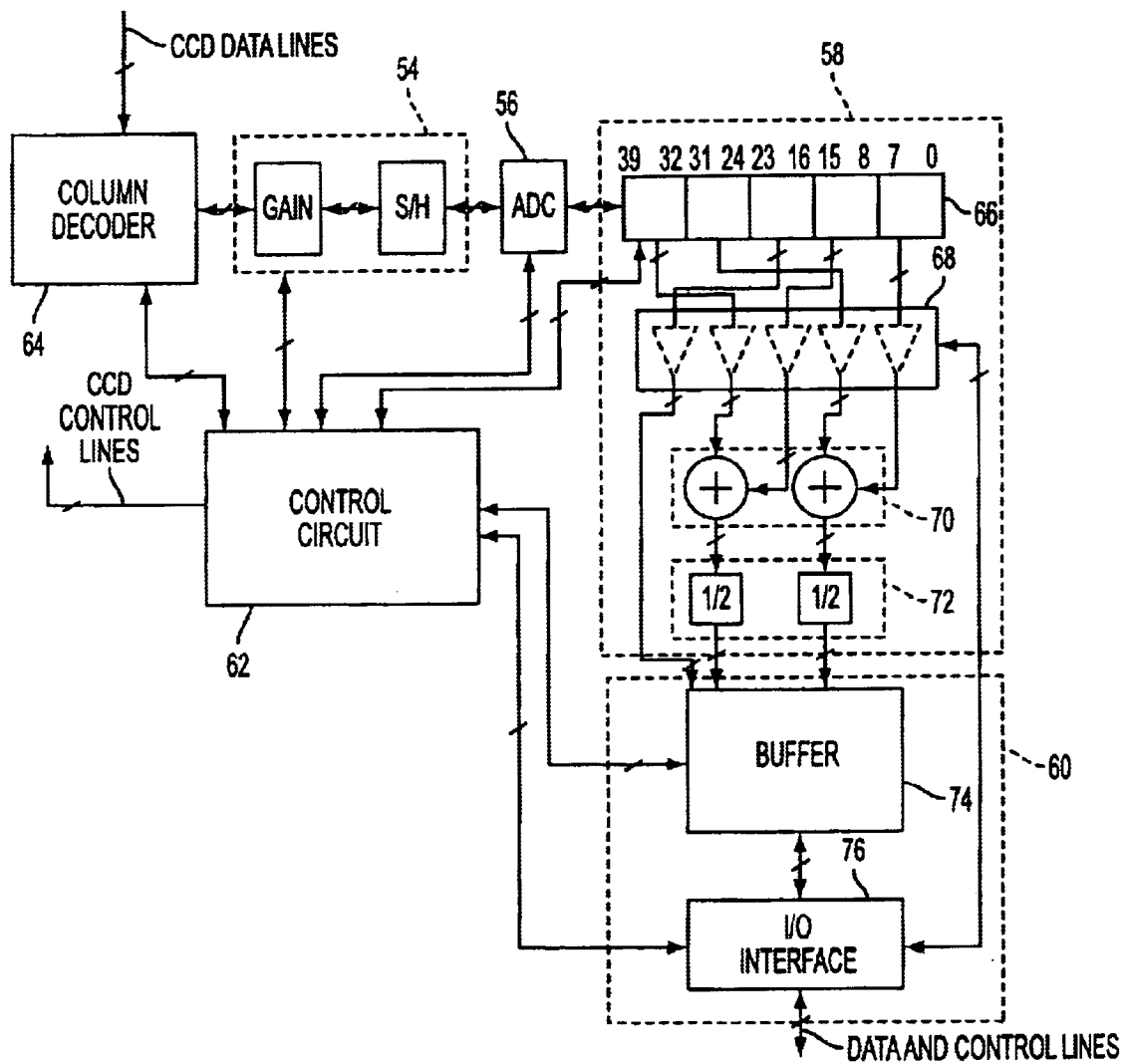

FIG. 6

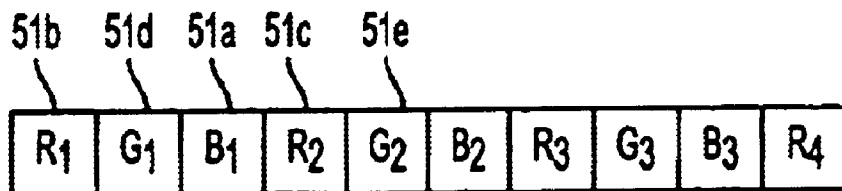

FIG. 7A

	G ₃	$\frac{3}{8} B_2 + \frac{3}{4} B_3$	$\frac{3}{8} R_4 + \frac{3}{4} R_3$	} 69
74	R ₃	$\frac{3}{8} G_2 + \frac{3}{4} G_3$	$\frac{3}{8} B_3 + \frac{3}{4} B_2$	
	B ₂	$\frac{3}{8} R_2 + \frac{3}{4} R_3$	$\frac{3}{8} G_3 + \frac{3}{4} G_2$	
	G ₂	$\frac{3}{8} B_1 + \frac{3}{4} B_2$	$\frac{3}{8} R_3 + \frac{3}{4} R_2$	
69b	R ₂	$\frac{3}{8} G_1 + \frac{3}{4} G_2$	$\frac{3}{8} B_2 + \frac{3}{4} B_1$	
69a	B ₁	$\frac{3}{8} R_1 + \frac{3}{4} R_2$	$\frac{3}{8} G_2 + \frac{3}{4} G_1$	

FIG. 7B

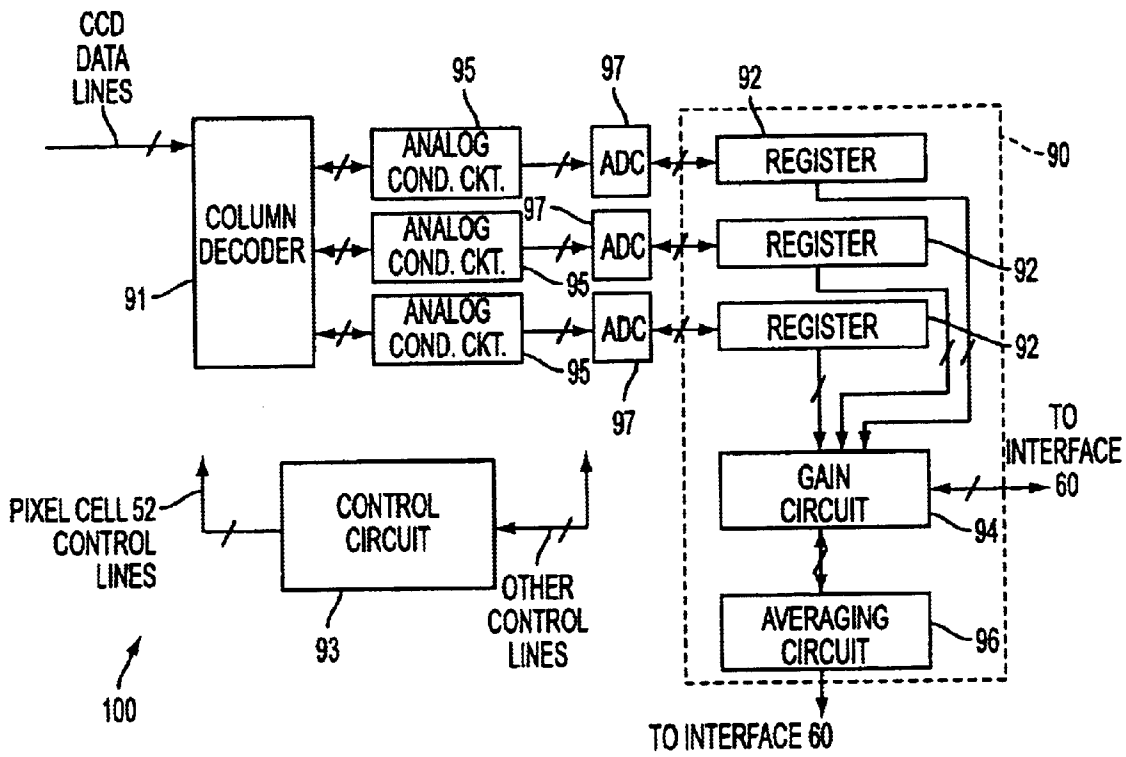

FIG. 8

INTERPOLATOR FOR A CMOS IMAGE SENSOR USING A DIGITAL REGISTER

BACKGROUND

The invention relates to color interpolation.

FIG. 1 shows a semiconductor imager **10** (e.g., a complementary metal-oxide semiconductor (CMOS) imager) might be used to electrically capture “snapshots” of an optical image. The imager is used to convert an optical image into an electrical representation. The imager **10** accomplishes this conversion through the use of an array of sensing elements arranged as pixel cells **12** that sense the intensity of light coming from the image. The “exposure time” for each snapshot depends on an integration interval during which each pixel cell **12** integrates an indication of the number of photons of light striking the cell **12** (i.e., measures an intensity of light striking the cell **12**) and provides an indication of the integrated value via an analog output signal. For CMOS imagers, on-chip analog conditioning circuitry **14** (e.g., circuitry to perform correlated double sampling and gain control) and an analog-to-digital converter (ADC) **16** process the analog outputs of the pixel cells **12** to provide a digital representation of the image which can be retrieved from the imager **10** through a parallel port interface **18**.

The pixel cells **12** provide an indication of the intensity of light striking the cell **12**. Hence, the above-described arrangement may be used to produce a monochrome or luminance only representation of the image. However, to produce color representations of the image, the imager also needs to provide information about primary colors (e.g., red, green and blue colors) of the image. To accomplish this, each pixel cell **12** is configured to sense the intensity level of light in one of the primary color bands. A typical way to accomplish this is to cover each pixel cell **12** with a spectrum-discriminating filter (e.g., a filter that only allows a red, green or blue color band to pass through the filter). As a result, some pixel cells **12** sense red light, some pixel cells **12** sense green light and some pixel cells **12** sense blue light. As an example, a multi-band filter pattern **20** (see FIG. 2) placed over the array of pixel cells **12** may have alternating red, green and blue filter stripes that extend along the columns of the array. Thus, each filter stripe of the pattern **20** configures one of the columns of the array to sense light in one of the primary color bands. As another example, the filter pattern may be checkered, instead of striped.

Each pixel cell **12** captures a portion of the image. To maximize the resolution of the image when reproduced on a display, it is desirable to form a one-to-one correspondence between the pixel cells **12** of the imager **10** and pixels of the display. However, with color imagers, three adjacent pixel cells **12** (each pixel cell **12** sensing a different primary color band) are typically used to provide the information needed to form one pixel on the display. Thus, when used to capture color images, the effective display pixel resolution of the imager **10** typically is one third of the actual pixel cell **12** resolution.

For purposes of preserving a one-to-one correspondence between the pixel cells **12** and the pixels of the display, one solution is to form an imager having three times as many pixel cells as corresponding pixels of the display to compensate for the three primary colors. Referring to FIG. 3, another solution is to use three imagers **22**, **24**, and **28**, one for each primary color band of the image. Thus, for example, one imager **22** (covered by a red filter) senses red light, one

imager **24** (covered by a green filter) senses green light, and one imager **26** (covered by a blue filter) senses the blue light coming from the image. Dichroic plates **28** may be used to split the light into beams into its primary colors.

Referring to FIG. 4, a third solution might be to use an off chip discrete-time signal processing (DSP) engine **30** to interpolate the two missing colors for each pixel cell **12**. To accomplish this, the DSP engine **30** processes the color information provided by adjacent pixel cells **12**. Typically, nearest neighbors are weighted with predetermined coefficients and averaged to determine a color at a particular pixel cell location. For example, referring back to FIG. 1, a pixel cell **12a** that is covered by a red filter provides a representation of a red color of the portion of the image striking the cell **12a**. To ascertain the blue color of the portion of the image otherwise striking the cell **12a** (if not for the red filter), the DSP engine **30** averages (a weighted representation of) the outputs of adjacent pixel cells **12b** and **12c** (i.e., adjacent pixel cells covered by a blue filter) to interpolate the missing blue color. The DSP engine **30** also interpolates the green color of the portion of the image that would otherwise strike the cell **12a** in a similar manner.

SUMMARY OF THE INVENTION

In general, in one aspect, the invention features an imager that has first and second photosensitive sites and an interpolator located in a semiconductor substrate. The first photosensitive site is configured to receive light having a spectral component, and the second photosensitive site is configured to measure the level of the spectral component in light received by the second photosensitive site. The interpolator is configured to estimate the level of the spectral component in the light received by the first photosensitive site based on the measurement by the second photosensitive site.

Implementations of the invention may include one or more of the following. The first and/or second photosensitive sites may include a pixel cell and a filter that covers the pixel cell. The filter covering the first photosensitive site may be configured to prevent the spectral component from striking the pixel cell, and the filter covering the second photosensitive site may be configured to allow the spectral component to strike the pixel cell. The first photosensitive site may also be configured to measure the level of another spectral component in light received by the first photosensitive site, and the interpolator may be also configured to estimate the level of another spectral component in the light received by the second photosensitive site based on the measurement by the first photosensitive site.

The imager may also include a third photosensitive site (also located in the substrate) that is configured to measure the level of the other spectral component in light received by the third photosensitive site. The first photosensitive site may also be configured to receive light having the another spectral component, and the interpolator may also be configured to estimate the level of the spectral components in the light received by the first photosensitive site based on the measurements by the second and third photosensitive sites.

In general, in another aspect, the invention features an imager that has first and second photosensitive sites and an interpolator located in a semiconductor substrate. Each first photosensitive site is configured to receive light having a spectral component, and each second photosensitive site is configured to measure the level of the spectral component in light received by the second photosensitive site. The interpolator is configured to estimate the level of the spectral

component in the light received by at least one of the first photosensitive sites based on the measurements by the second photosensitive sites.

Implementations of the invention may include one or more of the following. The interpolator may include an averaging circuit that is configured to perform the estimation by averaging some of the measurements by the second photosensitive sites. The interpolator may also include a scaling circuit that is configured to scale some of the measurements by predetermined coefficients before being averaged by the averaging circuit. The scaling circuit may be programmable to change one or more of the coefficients. The first and second photosensitive sites may be part of an array of photosensitive sites (e.g., located in a column of the array, a row of the array, or arranged in a rectangular block of an array).

In general, in another aspect, the invention features a color imager for use with light having first, second and third primary color bands. The imager has first, second and third photosensitive sites and an interpolator located in a semiconductor substrate. Each first photosensitive site is configured to receive a portion of the light and measure a level of the first primary color band in the portion of light received by the first photosensitive site. Each second photosensitive site is configured to receive a portion of the light and measure a level of the second primary color band in the portion of light received by the second photosensitive site. Each third photosensitive site is configured to receive a portion of the light and measure a level of the third primary color band in the portion of light received by the third photosensitive site. The interpolator is configured to estimate the levels of the second and third primary color bands in the light received by the first photosensitive sites based on the measurements by the second and third photosensitive sites; estimate the levels of the first and third primary color bands in the light received by the second photosensitive sites based on the measurements by the first and third photosensitive sites; and estimate the levels of the first and second primary color bands in the light received by the third photosensitive sites based on the measurements by the first and second photosensitive sites.

Implementations of the invention may include one or more of the following. The interpolator may be also configured to furnish a representation of the levels of the first, second and third primary color bands for each of the first, second and third photosensitive sites. The representation for each site may include a representation (e.g., a true color representation) of the color of the light received by the site.

In general, in another aspect, the invention features a method that includes using a first photosensitive site located in a semiconductor substrate to receive light having a spectral component. A second photosensitive site located in the substrate is used to measure the level of the spectral component in light received by the second photosensitive site. An interpolator located in the substrate is used to estimate the level of the spectral component in the light received by the first photosensitive site based on the measurement by the second photosensitive site.

In general, in another aspect, the invention features a method that includes using first photosensitive sites located in a semiconductor substrate to receive light having a spectral component. Second photosensitive sites located in the substrate are used to measure the level of the spectral component in light received by each of the second photosensitive sites. An interpolator located in the substrate is used to estimate the level of the spectral component in the

light received by at least one of the first photosensitive sites based on the measurements by the second photosensitive sites.

Among the advantages of the invention are one or more of the following. True color imaging occurs on a single semiconductor chip. The pixel cells of the imager and the pixels of the display have a one-to-one correspondence. Only one imager is required. The imager may be used with many commonly used color filter patterns.

Other advantages will become apparent from the following description and from the claims.

BRIEF DESCRIPTION OF THE DRAWINGS

FIG. 1 is a schematic view of a semiconductor imager.

FIG. 2 is a schematic view of color filters.

FIG. 3 is a block diagram of a system to interpolate color.

FIG. 4 is a schematic view of an optical system to separate light into primary color components.

FIG. 5 is a schematic view of a semiconductor imager.

FIG. 6 is an electrical schematic diagram of circuitry of the imager of FIG. 5.

FIG. 7A is a representation of the contents of the serial register of FIG. 6.

FIG. 7B is a representation of the contents of the buffer of FIG. 6.

FIG. 8 is an electrical schematic diagram of another imager.

DESCRIPTION OF THE PREFERRED EMBODIMENTS

FIG. 5 shows a CMOS imager **50** located on a monolithic semiconductor substrate, or chip. The illustrated embodiment is constructed to furnish twenty-four bit True Color data, e.g., eight bits representing a red color, eight bits representing a green color, and eight bits representing a blue color, for every photosensitive site **51**. Each photosensitive site **51** is a region of the imager **50** that includes a pixel cell **52**. As a result of this arrangement, a one-to-one correspondence between pixel cells **52** of the imager **50** and pixels of a display used to display the image captured by the imager **50** is preserved without requiring a larger imager, complicated optics, or off-chip color interpolation.

The imager **50** has an on chip color interpolator **58** which, for each photosensitive site **51**, estimates the level of the primary colors that are not sensed by the pixel cell **52** at that photosensitive site **51**. The color sensed by the pixel cell **52** is determined by a primary color filter of the site **51** that covers the pixel cell **52**. In this manner, the primary color filter (which is a red, green or blue filter) covers the cell **52**. Each cell **52** senses the level of light by measuring the intensity of the light in one of the primary color bands (e.g., red, green or blue) but does not sense the level of light in the other two primary color bands. The interpolator **58** estimates the missing color levels for the site **51** by using the outputs of pixel cells **52** in adjacent photosensitive sites **51** that are sensing these color levels.

The photosensitive sites **51** (and corresponding pixel cells **52**) are arranged in a rectangular array of rows and columns. To estimate the missing color levels for a given photosensitive site **51** (i.e. to estimate the color levels not sensed by the site **51**), the interpolator **58** may be configured to use pixel cells **52** in the same row, same column, or both (e.g., the interpolator **58** may use a block of pixel cells **52** that surround the given photosensitive site **51**). Although many

configurations are possible, as discussed below, a multi-band column oriented filter pattern (see FIG. 2) is assumed, and pixel cells 52 from the same row are used in the interpolation.

FIG. 6 shows analog conditioning circuitry 54 to perform correlated double sampling of the analog outputs of the pixel cells 52 and provide gain control. This circuitry receives the analog outputs of the pixel cells 52. The circuitry 54 furnishes its output to an analog-to-digital converter 56 which converts the analog outputs of the pixel cells 52 into digital data and supplies the digital data to the interpolator 58. After an integration interval has passed, the pixel cells 52 have captured a snapshot of the image. At that time a column decoder 64 begins routing the outputs of the pixel cell 52 to the analog conditioning circuitry 54 for processing. The decoder 64 sequentially selects one row of pixels 52 and serially provides the analog outputs of the pixel cells 52 of the row that is selected (i.e., provides all of the columns of the selected row) to the analog conditioning circuitry 54. A control circuit 62 controls the integration of the light by the pixel cells 52 and the overall timing of the imager 50. The True Color data may be read from the imager 50 at a parallel port interface 60.

The interpolator 58 estimates the levels of the missing color levels for a given photosensitive site 51 using the outputs of other pixel cells 52 that are close to the given photosensitive site 51. As one example, the interpolator 58 may be configured to use a one dimensional approach by serially processing photosensitive sites 51 and the corresponding pixel cells 52 at the photosensitive sites 51 from the same row of the array. The processing of a given photosensitive site 51 includes retrieving the color level sensed by the pixel cell 52 of the given photosensitive site 51 and estimating the missing color levels. The estimation uses the interpolator 58 to form the outputs of the last two pixel cells 52 that were processed and the next two pixel cells 52 to be processed to estimate the two missing color levels for the photosensitive site 51 currently being processed. The interpolator 58 performs a weighted average of the outputs from the pixel cells 52 to estimate the missing color levels.

For example, FIG. 7A shows a photosensitive site 51a is covered by a blue filter which filters out red and green light from striking the corresponding pixel cell 52. To estimate the red light that would otherwise strike the pixel cell 52 if not for the blue filter (i.e., to estimate the level of red light striking the photosensitive site 51a), the interpolator 58 forms a weighted average of the outputs of pixel cells 52 in adjacent photosensitive sites 51b and 51c that are covered by a red filter. Similarly, to estimate the green light that would otherwise strike the pixel cell 52 if not for the blue filter (i.e., to estimate the level of green light striking the photosensitive site 51a), the interpolator 58 uses a weighted average of the outputs of pixel cells 52 in adjacent photosensitive sites 51d and 51e that are covered by a green filter.

The estimate of color level for a given photosensitive site 51 uses a number of different values. The weight given by the interpolator 58 to the actual color level from another photosensitive site 51 is a function of the distance between the given photosensitive site 51 and the photosensitive site 51 furnishing the actual color level. For example, to estimate the level of green light striking the photosensitive site 51a (see FIG. 7A), the interpolator 58 might be configured to apply twice as much weight to the output of the pixel cell 52 in adjacent photosensitive site 51d than to the output of the pixel cell 52 twice as far away, such as pixel cell 52e.

FIG. 6 shows the hardware of the interpolator 58 including a five stage serial register 66. The least significant bits

zero to fifteen of the register contain eight bit digital representations of actual color levels for the last two photosensitive sites 51 and corresponding pixel cells 52 processed. The most significant bits twenty-four to thirty-nine of the register 66 contain eight bit digital representations of actual color levels for the next two photosensitive sites 51 and corresponding pixel cells 52 to be processed. The other bits sixteen to twenty-three of the register 66 contain an eight bit representation of the actual color level for the photosensitive site 51 and corresponding pixel cell 52 being processed.

Each photosensitive site 51 assembles the twenty-four bit True Color representation in a buffer 74 (of the parallel port interface 60) as follows. The interpolator 58 transfers the bits 16–23 of the register 66 which are representative of an actual color level, to the buffer 74 without any further processing. The interpolator 58 assigns a weight via scalar multipliers to the values represented by the bits 32–39 and 8–15 of the register 66. The interpolator 58 also averages (via adders 70 and a “divide-by-two” circuitry 72) these values to estimate one of the missing color values, and stores the resultant eight bit color value in the buffer 714. The twenty-four bit representation is completed by the interpolator 58 assigning a weight to the values represented by the bits 24–31 and 0–7, average these values together, and stores the resultant eight bit color value in the buffer 75. The twenty-four bit True Color value may then be retrieved from the buffer 74 (and from the parallel port interface 60) via an I/O interface 76 that is configured to communicate with off chip devices.

FIGS. 7A and 7B show the red-green-blue (“RGB”) byte ordering of the stored twenty-four bit color values 69 circularly rotates, and the most significant byte of the color value 69 corresponds to the actual color level sensed by the pixel cell 52 in the corresponding photosensitive site 51. As an example, for the twenty-four bit color value 69a representative of the color sensed by the pixel cell 52 in photosensitive site 51a, the most significant byte represents the actual blue color level (B1) sensed by the pixel cell in photosensitive site 51a, the next significant byte represents the estimated red color level for the photosensitive site 51a, and the least significant byte represents the estimated green color level for the photosensitive site 51a.

The gains of the scalar multipliers 68 (i.e., the weighting applied by the interpolator 58) may either be fixed or programmable. FIG. 6 shows the gains being programmable, with the I/O interface 76 having writable and readable registers used to program the gains of the multipliers.

The one dimensional color interpolation approach discussed above can be extended to two dimensional interpolation. In such an approach, the outputs from pixel cells 52 from more than one row are used to estimate the missing color levels of a photosensitive site 51. For example, FIG. 8 shows another interpolator 90 of another imager 100 having three serial, five stage registers 92. Similar to the register 66, each register 92 contains digital representations of five adjacent pixel cells 52 of one of three adjacent different rows. Each register 92 has representations from the same column of pixel cells 52. Thus, the bits of the registers 92 represent the outputs of a 5×3 block of pixel cells 52. The interpolator 90 includes analog conditioning circuitry 95 and an A/D converter 97 for each register 92. The integrator 90 also has a gain circuit 94 (e.g., scalar multipliers) and an averaging circuit 96 to provide weighted averaging for the interpolation. The imager 100 uses a column decoder 91 that has three serial outputs associated with three different adjacent rows of pixel cells 52. A control circuit 94 controls the

integration of the light by the pixel cells 52 and the overall timing of the imager 100.

Other embodiments are within the scope of the following claims. For example, other filter patterns, such as a checkerboard filter pattern may cover the array of pixel cells. The array may have more pixel cells dedicated to sensing one of the primary colors than to the other primary colors. For example, to improve the perceived luminance of the reproduced image, the array may have more pixel cells dedicated to sensing green (a color that closely matches the luminance of the human eye) color levels. The imager may represent color in a format other than a True Color representation. For example, six bits may be used to represent a green color level, five bits may be used to represent a blue color level, and five bits may be used to represent a red color level.

What is claimed is:

1. An imaging system comprising:
 - a semiconductor substrate;
 - a plurality of photosensitive pixels, located within said semiconductor substrate, each of said photosensitive pixels sensitive to a specified color of light and said plurality of photosensitive pixels collectively sensitive to at least three different primary colors of light;
 - an A/D conversion element, located in said substrate, and configured to produce digital values from at least a plurality of said photosensitive pixels;
 - an interpolator element, located within said semiconductor substrate, and receiving said digital values from said semiconductor substrate, and receiving said digital values from said A/D conversion element, said interpolator element including a register which stores bits of said digital values, and interpolates among said bits of said digital values to interpolate a level of a spectral component for one of said primary color pixels based on a received level of another primary color pixel.
2. An imaging system as in claim 1, wherein said plurality of photosensitive pixels includes a plurality of photoreceptors, and a plurality of color filters, each color filter configured to allow a specified color of light to pass to a specified photoreceptor.
3. An imaging system as in claim 1, wherein said photosensitive pixels includes CMOS image sensing pixels.
4. An imaging system as in claim 1, wherein said register stores bits of digital values for each of three primary colors for each of said plurality of photosensitive pixels.
5. An imaging system as in claim 4, wherein said register stores eight bits of a red color, eight bits of a green color and eight bits of a blue-color for each photosensitive pixel.
6. An imaging system as in claim 4, wherein said interpolator element determines bits of two different colors for each of said photosensitive pixels.
7. An imaging system as in claim 1, wherein said interpolator digitally weights certain values of certain bits in said register using scalar digital multipliers to estimate missing color values in said register.
8. An imaging system as in claim 1, wherein said interpolator digitally averages values to estimate missing color values.

9. An imaging system as in claim 1, wherein each group of bits within said interpolator element represents a color level for a specified primary color, and wherein a value of the color of the most significant group of bits of said register changes during each of a plurality of clock cycles.

10. An imaging system as in claim 9, wherein said group of bits is eight bits.

11. An imaging system as in claim 1, wherein said interpolator element includes a plurality of said registers, each register storing values from different pixel cells which neighbor a pixel cell being interpolated.

12. An imaging system as in claim 1, wherein a number of bits representing one of said primary color pixels is more than a number of bits representing another of said primary colors.

13. An imaging system as in claim 12, wherein said primary colors are red, green and blue, and more bits are assigned to green than to red and blue.

14. An imaging system as in claim 7, further comprising a plurality of registers which respectively store said digital weighting values.

15. A method, comprising:

receiving light in each of a plurality of photosensitive pixels;

converting values from one of said photosensitive pixels indicative of a specified primary color into digital values indicative of the incoming light;

storing said values within a specified location in a digital register within an interpolator element, and interpolating values from other color pixels to determine values of other colors other than said specified primary color, based on data from said other color pixels, and storing said values of other colors in other locations within said digital register.

16. A method as in claim 15, further comprising storing another value from another primary color in said digital register at a second time, whereby values of signals that are stored in specified bits of said digital register change between different times.

17. A method as in claim 16, wherein said digital register stores values for each of three primary colors.

18. A method as in claim 17, wherein said digital register stores values for each of red, green and blue.

19. A method as in claim 18, further comprising storing equal numbers of bits for each of said red, green and blue primary colors.

20. A method as in claim 18, further comprising storing unequal numbers of bits for some of said primary colors relative to others of said primary colors.

21. A method as in claim 15, wherein said interpolating comprises digitally weighting certain values of certain bits in said register using digital multipliers.

22. A method as in claim 15, wherein said interpolating comprises digitally averaging values in said register.