

(54) **PHOTODIODE-TYPE PIXEL FOR GLOBAL ELECTRONIC SHUTTER AND REDUCED LAG**

(75) Inventor: **Eric R. Fossum**, La Crescenta, CA (US)

(73) Assignee: **Micron Technology, Inc.**, Boise, ID (US)

(\* ) Notice: Subject to any disclaimer, the term of this patent is extended or adjusted under 35 U.S.C. 154(b) by 0 days.

(21) Appl. No.: **09/025,079**

(22) Filed: **Feb. 17, 1998**

(51) Int. Cl.<sup>7</sup> ..... **H04N 3/14; H04N 5/335**

(52) U.S. Cl. .... **348/308; 348/313**

(58) **Field of Search** ..... 348/308, 309, 348/301, 302, 303, 313, 314, 362, 296, 297; 257/292, 291, 237, 239, 216; 250/208.1

(56) **References Cited**

U.S. PATENT DOCUMENTS

4,369,378	A	*	1/1983	Rockett, Jr.	257/237
4,644,572	A	*	2/1987	Lambeth	257/216
4,684,800	A	*	8/1987	Morse et al.	257/237
4,686,648	A		8/1987	Fossum	
4,744,623	A		5/1988	Prucnal et al.	
4,776,925	A		10/1988	Fossum et al.	
4,839,735	A	*	6/1989	Kyomasu et al.	348/297
4,920,069	A		4/1990	Fossum et al.	
5,054,040	A	*	10/1991	Yariv et al.	257/237
5,055,900	A		10/1991	Fossum et al.	
5,080,214	A		1/1992	Fossum	
5,105,277	A	*	4/1992	Hayes et al.	348/313
5,236,871	A		8/1993	Fossum et al.	
5,343,297	A	*	8/1994	Tiemann et al.	348/306
5,386,128	A		1/1995	Fossum et al.	

5,471,515	A	11/1995	Fossum et al.	
5,548,773	A	8/1996	Kemeny et al.	
5,665,959	A	9/1997	Fossum et al.	
5,793,322	A	8/1998	Fossum et al.	
5,841,126	A	11/1998	Fossum et al.	
5,872,371	A	*	2/1999	Guidash et al. .... 257/292
5,880,691	A	3/1999	Fossum et al.	
5,886,659	A	3/1999	Pain et al.	
5,887,049	A	3/1999	Fossum	
5,909,026	A	6/1999	Zhou et al.	
5,920,345	A	*	7/1999	Sauer ..... 348/308
5,949,483	A	9/1999	Fossum et al.	
5,952,645	A	9/1999	Wang et al.	
5,990,506	A	11/1999	Fossum et al.	
5,995,163	A	11/1999	Fossum	
6,005,619	A	12/1999	Fossum	
6,008,486	A	12/1999	Stam et al.	
6,021,172	A	2/2000	Fossum et al.	
6,057,539	A	5/2000	Zhou et al.	
6,137,100	A	*	10/2000	Fossum et al. .... 250/208.1
6,166,768	A	*	12/2000	Fossum et al. .... 348/308
6,201,270	B1	*	3/2001	Chen ..... 257/292

\* cited by examiner

*Primary Examiner*—Aung S. Moe

(74) *Attorney, Agent, or Firm*—Dickstein Shapiro Morin & Oshinsky LLP

(57) **ABSTRACT**

Operation for global electronic shutter photodiode-type pixels. In a first mode of operation, lag is reduced through global reset of the photodiode array and fixed pattern noise is eliminated through comparison of the photosignal level and the reset level of the floating drain. In a second mode of operation, simultaneous integration and readout processes are achieved through cessation of spill charges over the transfer gate. In a third mode of operation, regulation of the reset photodiode and transfer gate enables voltage gain between the photodiode and the sense node.

**2 Claims, 8 Drawing Sheets**

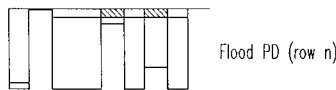
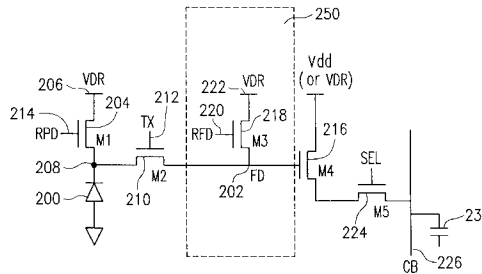

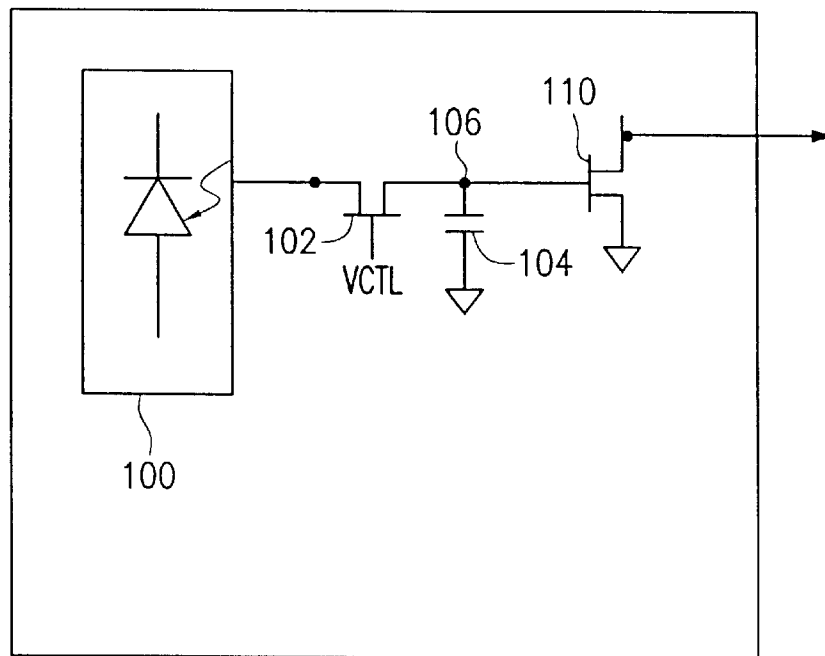

FIG. 1

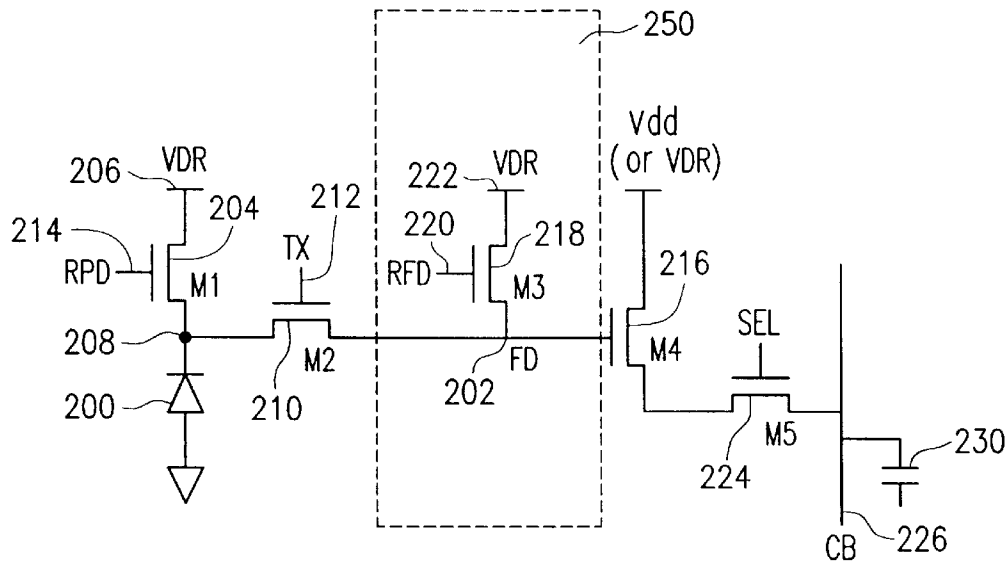

FIG. 2A

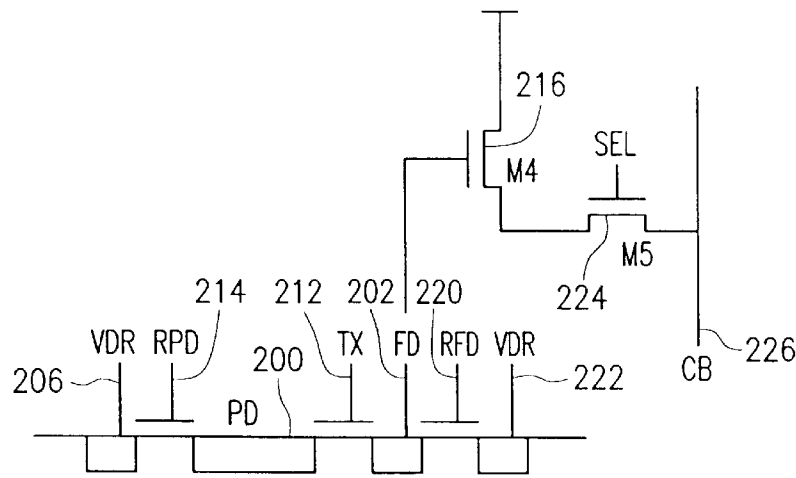

FIG. 2B

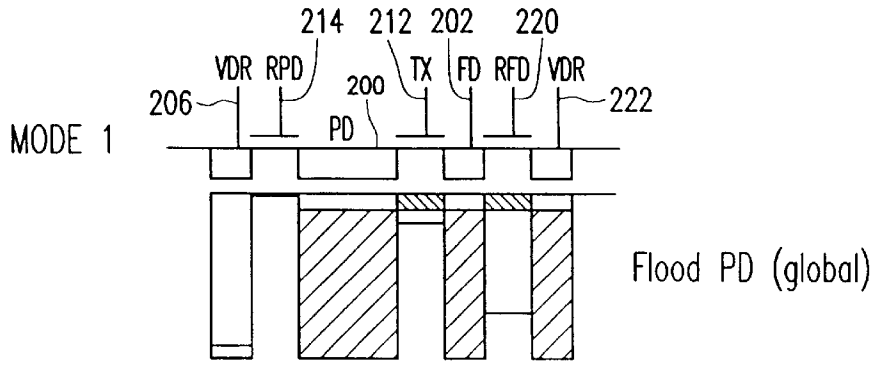

FIG. 3A

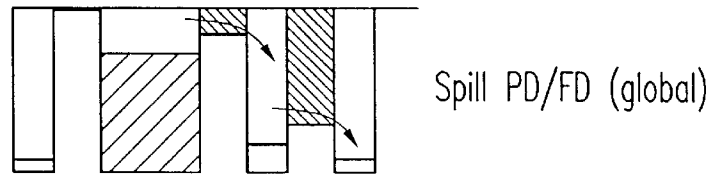

FIG. 3B

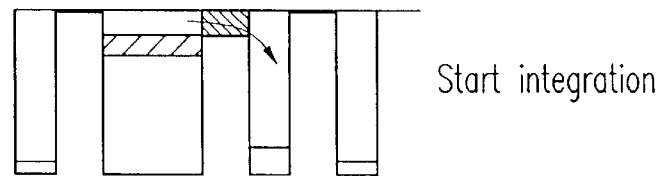

FIG. 3C

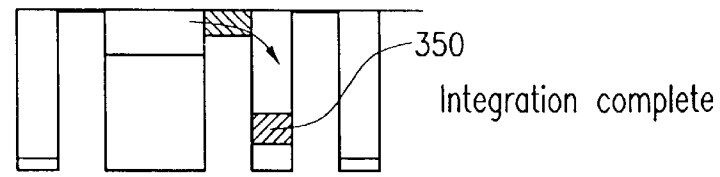
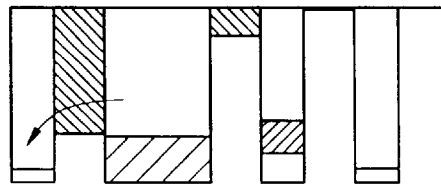
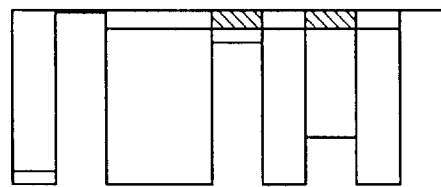

FIG. 3D



Shutter closed  
Start reading rows  
Read row n FD

**FIG. 3E**



Flood PD (row n)

**FIG. 3F**

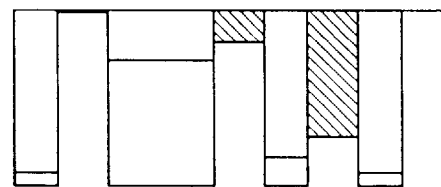

Spill PD/FD (row n)

**FIG. 3G**

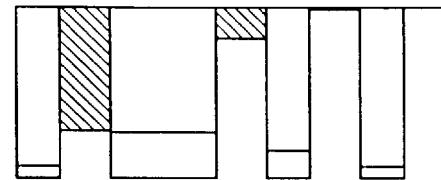

Move on to row n+1

**FIG. 3H**

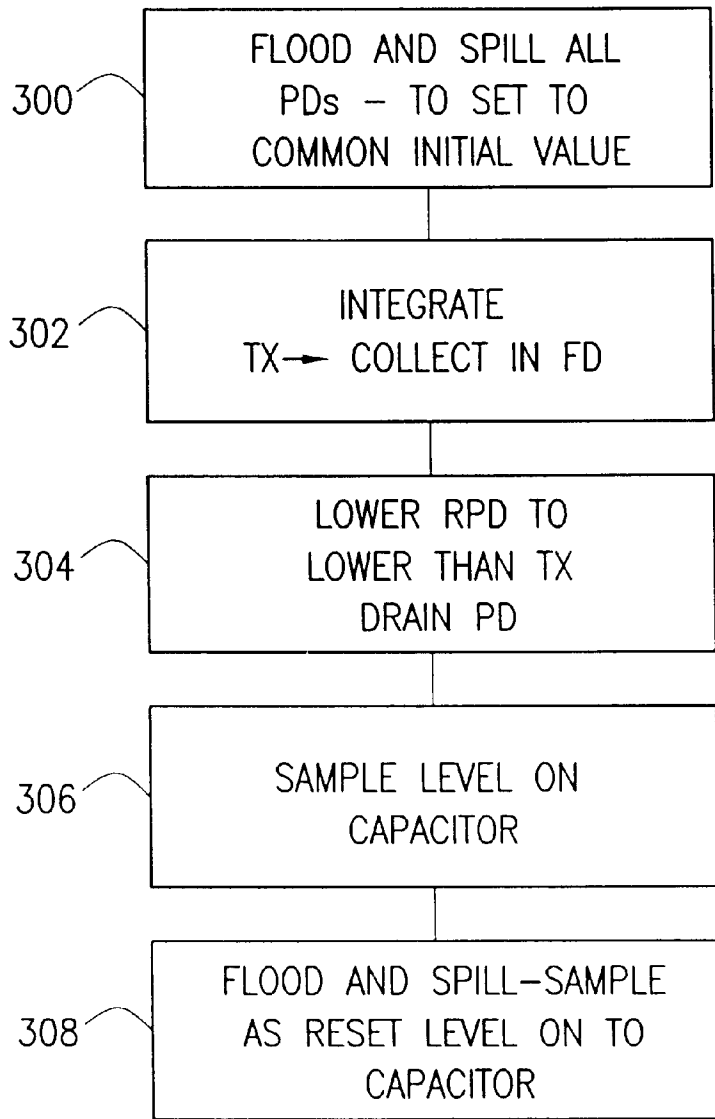

FIG. 3I

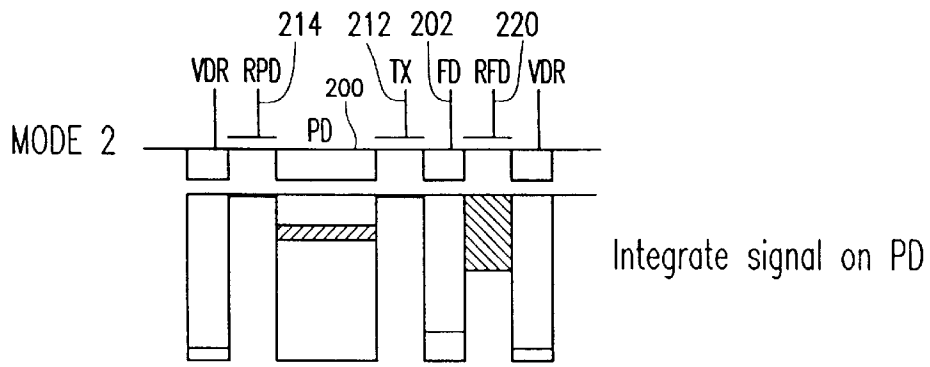

FIG. 4A

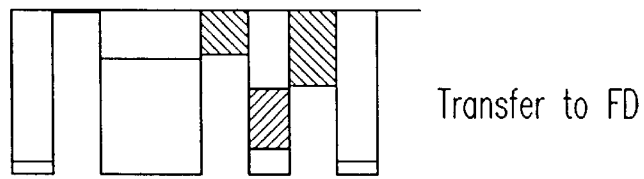

FIG. 4B

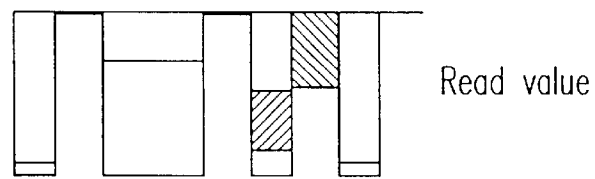

FIG. 4C

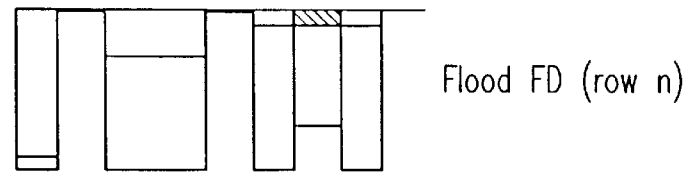

FIG. 4D

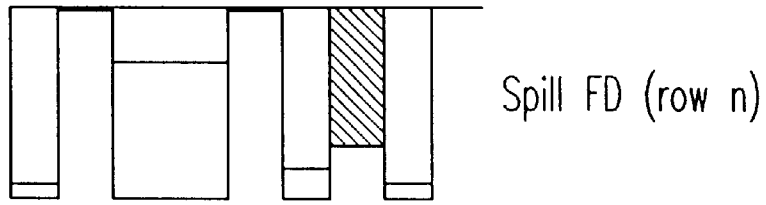

FIG. 4E

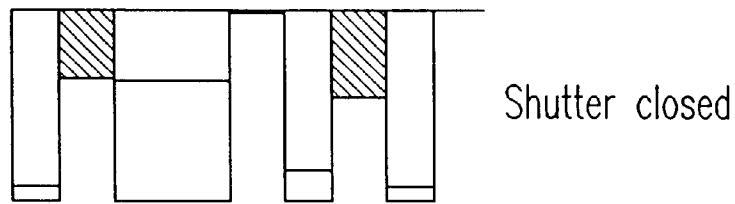

FIG. 4F

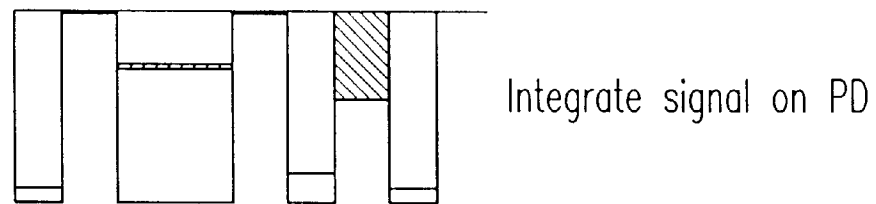
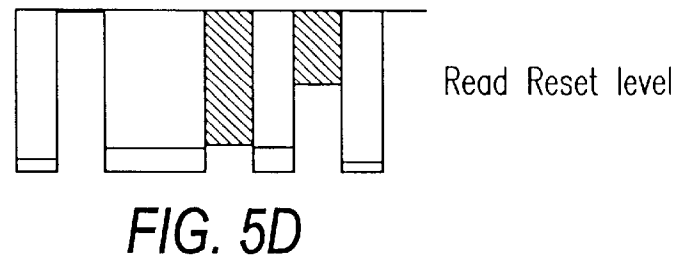
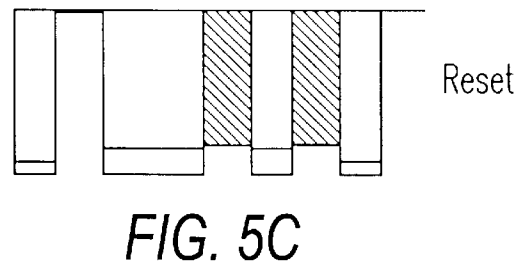
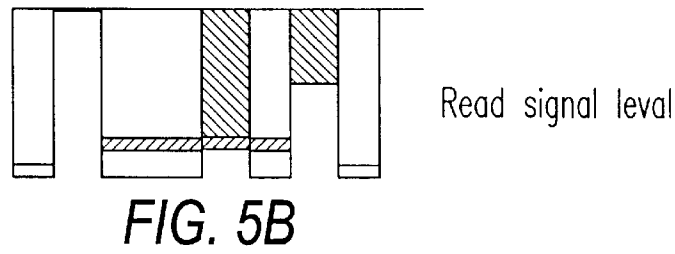
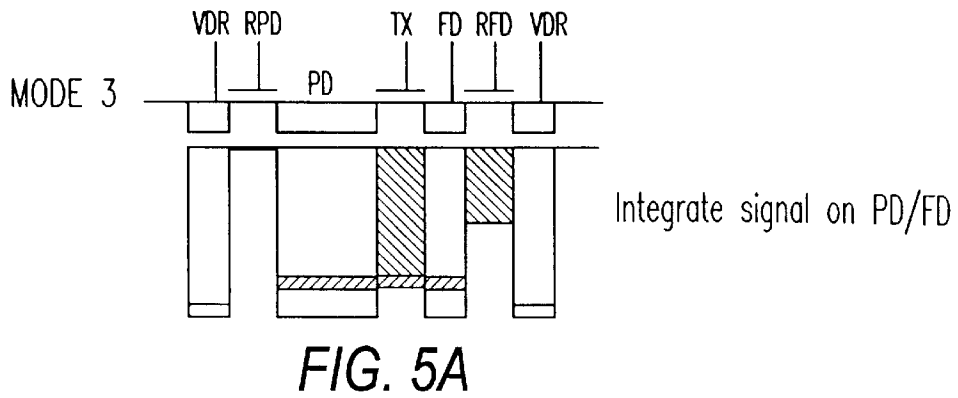

FIG. 4G





# PHOTODIODE-TYPE PIXEL FOR GLOBAL ELECTRONIC SHUTTER AND REDUCED LAG

## TECHNICAL FIELD

This disclosure relates to active image capturing using photodiodes. More particularly, the present disclosure describes to active pixel devices using photodiodes as their active elements.

## BACKGROUND

Active pixel devices include a light sensing element, and internal image processing structure. Many active pixel sensors, such as that described in U.S. Pat. No. 5,471,515, the disclosure of which is incorporated by reference herein, have a buffer structure, e.g., a source follower, as part of each pixel.

Active pixel sensors can use photodiodes or photogates, or other light sensitive elements. In many photodiode type active pixels, the light sensitive element is directly connected to the active pixel amplifier and/or buffer.

A global shutter effect commands all the pixels to integrate for the same short absolute period of time. This effectively freezes the motion of objects. However, in a photodiode device, an external light blocking shutter has typically been used to stop the photodiode from accumulating photosignal.

FIG. 1 shows one approach. A sampling switch **102** and capacitor **104** are used. Sampling switch **102** is placed between the photodiode **100** and the capacitor **104**. The capacitor charge node **106** is connected to the active pixel amplifier **110**. The photodiode voltage is sampled by a closing switch **102** and allowing the charge from the photodiode to charge sampling capacitor **104**. Switch **102** and capacitor **104** are covered by a metallic light shield to avoid pickup of undesirable light signal. This allows freezing the charge output at any given time.

However, the charge from the photodiode **100** is shared onto the capacitor **104** in the voltage domain. When the switch **102** is closed, the charge flows from the photodiode **102** in order to equalize the voltage between photodiode output and capacitor **106** node. Thus, the maximum signal-induced voltage swing of the capacitor **104** may be limited by the voltage of the photodiode. Since charge is shared, the voltage swing is in fact, always lower. Furthermore, turning off the sampling switch may itself inject charge to the sampling capacitor. This, in turn, adds offset and noise.

## SUMMARY

The present disclosure describes an approach to this drawback described above. This is done by enabling voltage gain between the photodiode **100** and its sensing node.

The embodiment reduces lag in a photodiode-type active pixel for a global electronic shutter. More particularly, the invention operates in three modes to achieve improved image quality and photodiode performance.

In the first mode of operation, an image is captured by a photodiode array. Lag is reduced when the photodiodes are globally reset by a flood and spill of charge cycle. A readout phase follows the reset phase. During this second phase, image quality is improved by the elimination of fixed pattern noise through the comparison of the photosignal level and the reset level of the floating drain.

In the second mode of operation, global shutter simultaneous integration and readout processes are achieved by

cessation of charges which trickle out over the transfer gate as in the first mode.

In the third mode of operation, lower conversion gain of a combined photodiode is achieved by restoring the sensor to normal operation through regulation of the reset photodiode and the transfer gate.

The details of one or more embodiments of the invention are set forth in the accompanying drawings and the description below. Once the details of the invention are known, numerous additional innovations and changes will become obvious to one skilled in the art.

## DESCRIPTION OF DRAWINGS

FIG. 1 is a diagram of an embodiment of a photodiode type active pixel.

FIG. 2A is a diagram of a photodiode-type active pixel in accordance with the invention.

FIG. 2B is a detailed diagram of the photodiode-type active pixel in accordance with the invention.

FIGS. 3A–3H are diagrams of a photosignal integration and readout phase operation in accordance with the invention.

FIG. 3I is a diagram in flow chart form showing operation of a photodiode type active pixel according to one aspect of the invention.

FIGS. 4A–4G are diagrams of a photosignal integration and readout phase operation for simultaneous integration and readout processes in accordance with the invention.

FIG. 5 is a diagram of a photosignal integration and readout phase operation for a combined photodiode with lower conversion gain in accordance with the invention.

Like reference numbers and designations in the various drawings indicate like elements.

## DETAILED DESCRIPTION

An embodiment is shown in FIGS. 2A and 2B. This embodiment minimizes the problem of charge injection, and also reduces lag.

FIG. 2A shows a schematic view of the preferred circuit. Photodiode **200** is connected to the source of FET **204** whose drain is connected to a bias voltage level VDR **206**. FET **204** is used to reset the photodiode. Signal RPD **214** controls reset of the photodiode.

FET **210** also connects the photodiode output node **208** to a floating diffusion (“FD”) node **202**. FD has a capacitance of approximately 0.016 pf (or 10  $\mu\text{V}/e^-$ ). FET **210** is driven by a signal applied to transfer gate TX **212**. Preferably, the FET is de-biased in a 5 volt n-well implementation at about 1 volt.

FD **202** is connected to the gate of source-follower FET **216** which acts as a buffer and amplifier. The output is gated by selector transistor **224**, and selectively driven to column bus **226**.

The voltage on FD **202** is also reset under control of FET **218**. FET **218** is driven by reset floating diffusion control voltage RFD **220**. The reset transistor **218** resets the node to the level of voltage VDR **222**.

FIG. 2B shows the same circuit in transistor well form. While FIG. 2A shows these devices as transistors, FIG. 2B shows them more accurately as gates and wells.

The operation of the image sensor in a first mode of operation is explained with reference to FIGS. 3A–3H, and the flowchart of FIG. 3I. This sensor operates in two

phases—an image acquisition phase, and an image readout phase. This preferred mode of the sensor separates read out from integration in order to allow a simultaneously integrating electronic shutter and the dual sampling for fixed pattern noise reduction.

The inventors recognized that lag is caused by an initial value in the photodiode at a beginning of integration. This embodiment starts with a global reset of the photodiodes at **300** and in the state shown in FIG. 3A. All photodiodes in the entire array are operated simultaneously. Voltage drain VDR **222** is initially set to 5 volts and RPD **214** is off. RFD **220** is turned on and VDR **206** is set to ground. This floods photodiode **200** and FD **202** with charge, as shown in FIG. 3A.

After approximately 1  $\mu$ s, VDR **222** is returned to 5 volts as shown in FIG. 3B. This causes the flooded PD **200** to spill out over transfer gate TX **212** to the level set by the bias on **212**. It also causes the charge on FD to spill over transistor **218**'s RFD barrier to VDR **222**. This spill cycle also lasts approximately 1  $\mu$ s.

The flood and spill ensures that the initial conditions on PD **200** will be the same for all frames and that its initial state is erased. Since all initial conditions are the same, artifacts, and hence lag, is eliminated or reduced.

After the reset, PD **200** integrate the photosignal for the desired integration period, as step **302** in FIG. 3I, and as shown in FIG. 3C. The initial flood and spill has left the PD charged to the level of the TX barrier. Hence, as the photosignal is collected, it trickles over TX **212** barrier and is collected by FD **202** as collected charge **350**.

The change in voltage on node FD **202** is determined by its capacitance and is estimated above to be  $10 \mu\text{V}/e^-$ .

The integration period is ended by setting RPD **214** to 5 volts, as shown in FIG. 3E. This effectively closes the shutter by draining all additional photoelectrons from PD down to the level of the RPD, over the transistor **210** barrier to the drain level VDR **206**. The barrier RPD is kept lower than TX **212** to ensure that the photoelectrons are drained away and not into the FD, as shown in step **304**. Hence, the photosignal is held on FD **202**. FD **202** is covered by a light shield **250** and protected from unwanted light signal. The output of the floating diffusion drives the high impedance input of a source follower transistor **216**. The signal is hence stored as long as RPD **214** remains on. This continues until after the pixel is selected for readout.

In the readout phase, pixels are selected a row at a time by the select transistor **224**. When enabled, the voltage on the output of the source follower transistor **216** is driven onto the column output bus CB **226**. When the row is first selected, the voltage is sampled onto capacitor **230** at **306**. This represents the photosignal level (VS). Photodiode **200** and output node FD **202** is then reset by another flood and spill sequence as above, and shown in 3F and 3G. The cycle is timed identically to the global reset described above. At the completion of the cycle, RFD **220** is set low and FD **202** is sampled. This represents the reset level (VR) of the floating drain FDR. That voltage is sampled on to capacitor **230** to form a difference between VS and VR which is proportional to the integrated light signal during the integration period. By taking the difference, fixed pattern noise introduced by transistor threshold non-uniformities and possibly timing skew across rows is minimized, thereby improving image quality. After subsequent processing (e.g., analog and digital conversion and readout), the next row is selected for readout, as shown in FIG. 3H.

FIG. 3I is a flow diagram showing operation of an embodiment of the invention according to the above-described process. The illustrated process steps include “Flood and spill all photodiodes to set to a common initial value” **300**, “Integrate, TX and collect in FD” **302**, Lower RPD to lower than TX drain PD” **304**, “Sample level on capacitor” **306** and “Flood and spill — sample as reset level on to capacitor” **308**.

This process repeats until all rows desired for readout have been read out. The sensor then returns to its integrate mode.

Because charge is transferred in a trickle mode between the PD **200** and FD **202**, operations affecting either node during integration and prior to readout may adversely affect the accuracy.

An alternative mode **2** is illustrated in FIGS. 4A–4E. In mode **2**, charge is not continuously trickled over the TX **212** barrier. After the flood and spill cycle of FIGS. 3A and 3B, TX **212** is set low (to ground) as shown in FIG. 4A. This causes the photodiode to integrate the incoming charge. Charge can then be transferred to FD **202** all at once, at a desired time. TX **212** is returned to its initial spill value. This transfers the excess charge obtained since the spill of FIG. 3b from PD **200** is to FD **202**. FD **202** can then be read out as shown in FIG. 4C. The reset level of FD is estimated by performing the flood and spill operation with TX **212** set low, as shown, respectively, in FIGS. 4D and 4E. This allows simultaneous integration and readout processes.

FIGS. 4F and 4G show how the shutter can be closed by enabling RPD to allow incoming charge to spill over the barrier.

This mode does not describe PD **200** being flooded between frames. RPD **214** can still be used to control the integration duty cycle, with transfer to FR **202** only during the inter-frame planking interval. However, since the threshold voltages of RPD **214** and RFD **220** may not be equal, some offset nonuniformity can be expected.

If RPD **214** is a little deeper than RFD **220** for the same applied gate voltage, PD **200** will have a “pocket” that will result in reduced signal for low light levels.

Operation of the image sensor in mode **3** is illustrated in FIG. 5. This is a diagram of a photosignal integration and readout phase for a combined photodiode with lower conversion gain in accordance with the invention.

The sensor can be restored to “normal” photodiode APS operation by keeping RPD **214** off. TX **212** is biased at Vdd. This creates a combined photodiode of PD **200** and FD **202**. FIG. 5A shows integrating the incoming signal on the combined PD/FD. The signal is read by sampling the source follower **216** in FIG. 5B. The PD/FD combination is then reset in FIG. 5C by turning on RFD and hence draining the PD/FD combination. At FIG. 5D, that reset level is read for correction of the reset level.

Other embodiments are contemplated. For example, different switching elements could be used. Different channel conductivities allows the biasing to be done differently. All such modifications are intended to be encompassed within the following claims.

What is claimed is:

1. A method, comprising:

initially, resetting a plurality of photodiodes in image sensing array, by initially flooding each of said photodiodes with charge, and then allowing each of said photodiodes to spill to a common initial value;

**5**

after said resetting, integrating for the desired integration, in each of said photodiodes, and allowing charge to trickle continuously into a collection node during said integrating;

after said integrating, sampling a signal level by determining a level of charge on said collection node;

again filling and spilling said plurality of photodiodes in said image sensing array, after said sampling;

**6**

second sampling a level of said photodiodes as a reset level; and

taking a difference between said signal level and said reset level as an output value from each pixel.

2. A method as in claim 1, wherein said first sampling and said second sampling are carried out by transferring a voltage on to a capacitor.

\* \* \* \* \*