

(12) **United States Patent**
Fossum et al.

(10) **Patent No.:** **US 6,555,842 B1**
(45) **Date of Patent:** ***Apr. 29, 2003**

- (54) **ACTIVE PIXEL SENSOR WITH INTRA-PIXEL CHARGE TRANSFER**
- (75) Inventors: **Eric R. Fossum**, LaCrescenta, CA (US); **Sunetra Mendis**, Pasadena, CA (US); **Sabrina E. Kemeny**, LaCrescenta, CA (US)
- (73) Assignee: **California Institute of Technology**, Pasadena, CA (US)
- (*) Notice: Subject to any disclaimer, the term of this patent is extended or adjusted under 35 U.S.C. 154(b) by 31 days.

4,959,727 A	9/1990	Imaide et al.
5,097,339 A	3/1992	Ishida et al.
5,134,488 A	7/1992	Sauer
5,153,421 A	10/1992	Tandon et al.
5,182,623 A	1/1993	Hynecek
5,198,654 A	3/1993	Mukainakano et al.
5,225,696 A	7/1993	Bahraman
5,262,871 A	11/1993	Wilder et al.
5,317,174 A	5/1994	Hynecek
5,335,015 A	8/1994	Cooper et al.
5,341,008 A	8/1994	Hynecek
5,345,266 A	* 9/1994	Denyer 348/300
5,369,039 A	11/1994	Hynecek

(List continued on next page.)

FOREIGN PATENT DOCUMENTS

EP 0 700 582 B1 7/1998

OTHER PUBLICATIONS

Renshaw, D., et al., "ASIC Vision," Custom Integrated Circuits Conference, IEEE, pp. 7.3.1-7.3.4 (May 1990).

(List continued on next page.)

Related U.S. Application Data

- (63) Continuation of application No. 08/558,521, filed on Nov. 16, 1995, now Pat. No. 6,101,232, which is a continuation of application No. 08/188,032, filed on Jan. 28, 1994, now Pat. No. 5,471,515.
- (51) **Int. Cl.⁷** **H01L 29/04**
- (52) **U.S. Cl.** **257/59; 257/222; 257/232; 257/234; 257/239; 257/292; 257/294**
- (58) **Field of Search** **257/222, 232, 257/234, 239, 292, 294**

References Cited

U.S. PATENT DOCUMENTS

4,363,963 A	12/1982	Ando
4,525,742 A	6/1985	Nishizawa et al.
4,631,400 A	12/1986	Tanner et al.
4,660,090 A	4/1987	Hynecek
4,835,617 A	5/1989	Todaka et al.
4,839,729 A	6/1989	Ando et al.
4,839,735 A	6/1989	Kyomasu et al.
4,942,474 A	7/1990	Akimoto et al.

Primary Examiner—David Nelms
Assistant Examiner—Mai-Huong Tran
(74) *Attorney, Agent, or Firm*—Fish & Richardson P.C.

(57) **ABSTRACT**

An imaging device formed as a monolithic complementary metal oxide semiconductor integrated circuit in an industry standard complementary metal oxide semiconductor process, the integrated circuit including a focal plane array of pixel cells, each one of the cells including a photogate overlying the substrate for accumulating photo-generated charge in an underlying portion of the substrate, a readout circuit including at least an output field effect transistor formed in the substrate, and a charge coupled device section formed on the substrate adjacent the photogate having a sensing node connected to the output transistor and at least one charge coupled device stage for transferring charge from the underlying portion of the substrate to the sensing node.

19 Claims, 2 Drawing Sheets

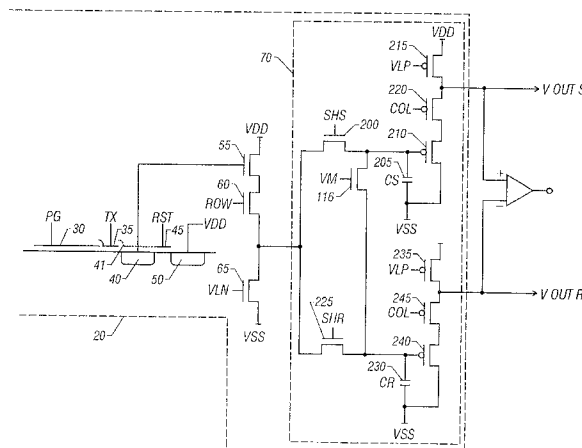

U.S. PATENT DOCUMENTS

5,420,634	A	5/1995	Matsumoto
5,424,223	A	6/1995	Hynecek
5,436,476	A	7/1995	Hynecek
5,452,004	A	9/1995	Roberts
5,452,109	A	9/1995	Compton
5,471,245	A	11/1995	Cooper et al.
5,471,515	A	11/1995	Fossum et al.
5,495,337	A	2/1996	Goshorn et al.
5,541,402	A	7/1996	Ackland et al.
5,585,620	A	12/1996	Nakamura et al.
5,608,204	A	3/1997	Höflinger et al.
5,631,704	A	5/1997	Dickinson et al.
5,652,622	A	7/1997	Hynecek

OTHER PUBLICATIONS

- Anderson, S., et al., "A Single Chip Sensor & Image Processor for Fingerprint Verification," Custom Integrated Circuits Conference, IEEE, pp. 12.1.1–12.1.4 (1991).
- Wang, G., et al., "CMOS Video Camera," University of Edinburgh, IEEE, pp. 100–132, (Mar. 1991).
- Denyer, P.B., et al., "CMOS Image Sensors for Multimedia Applications," Custom Integrated Circuits Conference, IEEE, pp. 11.5.1–11.5.4 (Mar. 1993).
- Eric R. Fossum, "Active Pixel Sensors: Are CCD's Dinosaurs?," Proceedings of the SPIE, vol. 1990, Charge-Coupled Devices and Solid-State Optical Sensors III, pp. 1–13 (1993).
- S. Chamberlain, "Photosensitivity and Scanning of Silicon Image Detector Arrays," IEEE J. Solid State Circuits, vol. SC-4, No. 6, pp. 333–342 (Dec. 1969).
- M. Aoki, et al., "2/3 Inch Format MOS Single-Chip Color Imager," IEEE Trans. On Electron Devices, vol. ED-29, No. 4, pp. 745–750 (Apr. 1982).
- J. Hynecek, "A New Device Architecture Suitable for High-Resolution and High-Performance Image Sensors," IEEE Trans. on Electron Devices, vol. 35(5), pp. 646–652 (May 1988).
- F. Andoh, et al., "A 250,000-Pixel Image Sensor with FET Amplification at Each Pixel for High-Speed Television Cameras," 1990 IEEE International Solid-State Circuits Conference, Digest of Technical Papers, pp. 212–213 (Feb. 16, 1990).
- N. Tanaka, et al., "A 310K Pixel Bipolar Imager (BASIS)," IEEE Trans. On Electron Devices, vol. 37(4), pp. 964–971 (Apr. 1990).
- K. Chen, et al., "PASIC: A Processor-A/D converter-Sensor Integrated Circuit," IEEE ISCAS, pp. 1705–1708 (1990).
- O. Yadid-Pecht, et al., "A Random Access Photodiode Array for Intelligent Image Capture," IEEE Trans. on Electron Devices, vol. 38, No. 8, pp. 1772–1780 (Aug. 1991).
- M. Kyomasu, "A New MOS Imager Using Photodiode as Current Source," IEEE Journal of Solid State Circuits, vol. 26, No. 8, pp. 1116–1122 (Aug. 1991).
- R. Forchheimer, et al., "MAPP2200—A Second generation smart optical sensor," Proc. SPIE, vol. 1659, pp. 2–11 (1992).
- C. Jansson, et al., "An Addressable 256x256 Photodiode Image Sensor Array with an 8-Bit Digital Output," Analog Integrated Circuits and Signal Processing, vol. 4, pp. 37–49 (1993).
- H. Kawashima, et al., "A 1/4 Inch Format 250K Pixel Amplified MOS Image Sensor Using CMOS Process," IEEE IEDM Tech. Digest, pp. 22.4.1–22.4.4 (1993).
- S. Mendis, et al., "Design of a Low-Light-Level Image Sensor with On-chip Sigma-Delta Analog-to-Digital Conversion," SPIE, Charge Coupled Devices & Solid State Optical Sensors III, vol. 1900, pp. 31–39 (1993).
- M. Sugawara, et al., "An Amplified MOS Imager Suited for Image Processing," 1994 IEEE International Solid-State Circuits Conference, Digest of Technical Papers, Session 13, Neural Networks and Image Sensors/Paper TP 13.6, pp. 228–229 (1994).
- B. Pain, et al., "Approaches and analysis for on-focal-plane analog-to-digital conversion," Proc. SPIE, vol. 2226, pp. 208–218 (1994).
- A. Gruss, et al., "Integrated Sensor and Range-Finding Analog Signal Processor," IEEE Journal of Solid State Circuits, vol. 26, No. 3, pp. 184–191 (Mar. 1991).
- Renshaw, et al., "ASIC Image Sensors," Proc. IEEE ISCAS, pp. 3038–3041 (1990).
- O. Vellacott, "CMOS in camera," IEE Review, pp. 111–114 (May 1994).
- I. Muirhead, "Developments in CMOS Camera Technology," published by: IEE, Savoy Place, London WC2R 0BL, UK, pp. 5/1–5/4 (1994).
- I. Takayanagi, et al., "A Multiple Output CMD Imager for Real-Time Image Processing," IEEE, IEDM, pp. 22.5.1–22.5.4 (1993).
- M. White, et al., "Characterization of Surface Channel CCD Image Arrays at Low Light Levels," IEEE Journal of Solid-State Circuits, vol. SC-9, No. 1, pp. 1–13 (Feb. 1974).
- W. Yang, et al., "A full-fill factor CCD imager with integrated signal processors," IEEE International Solid-State Circuits Conference Digest of Technical Papers, pp. 218–219 and 300 (Feb. 16, 1990).
- R. Forchheimer, "Single-chip image sensors with a digital processor array," Journal of VLSI Signal Processing, vol. 5, pp. 121–131 (1993).
- E. Fossum, et al., "Development of CMOS Active Pixel Image Sensors for Low Cost Commercial Applications," Conference Proceedings of NASA Technology 2004, pp. 1–2 (Nov. 1994).
- E. Fossum, et al., "Application of the active pixel sensor concept to guidance and navigation," SPIE, vol. 1949, Space Guidance, Control and Tracking, paper 30, pp. 1–8 (1993).
- E. Fossum, "Assessment of Image Sensor Technology for Future NASA Missions," Proceedings of the SPIE, vol. 2172, Charge-Coupled Devices and Solid-State Optical Sensors IV, pp. 1–16 (1994).
- T. Kuriyama, et al., "A 1/3-in 270 000 Pixel CCD Image Sensor," IEEE Transaction on Electron Devices, Special Issue on Solid State Image Sensors, vol. 38, No. 5, pp. 949–953 (May 1991).
- J. Hojo, et al., "A 1/3-in 510(H)x492(V) CCD Image Sensor with Mirror Image Function," IEEE Transaction on Electron Devices, Special Issue on Solid State Image Sensors, vol. 38, No. 5, pp. 954–959 (May 1991).
- H. Ando, et al., "A 1/2-in CCD Imager with Lateral Overflow-Gate Shutter," IEEE Transaction on Electron Devices, Special Issue on Solid State Image Sensors, vol. 38, No. 5, pp. 960–964 (May 1991).
- A. Toyoda, et al., "A Novel Tungsten Light-Shield Structure for High-Density CCD Image Sensors," IEEE Transaction on Electron Devices, Special Issue on Solid State Image Sensors, vol. 38, No. 5, pp. 965–968 (May 1991).

- T. Ozaki, et al., "A Low-Noise Line-Amplified MOS Imaging Devices," *IEEE Transaction on Electron Devices, Special Issue on Solid State Image Sensors*, vol. 38, No. 5, pp. 969-975 (May 1991).
- M. Yamagishi, et al., "A 2 Million Pixel FIT-CCD Image Sensor for HDTV Camera Systems," *IEEE Transaction on Electron Devices, Special Issue on Solid State Image Sensors*, vol. 38, No. 5, pp. 976-980 (May 1991).
- E. Stevens, et al., "A 1-Megapixel, Progressive-Scan Image Sensor with Antiblooming Control and Lag-Free Operation," *IEEE Transaction on Electron Devices, Special Issue on Solid State Image Sensors*, vol. 38, No. 5, pp. 981-988 (May 1991).
- K. Matsumoto, et al., "The Operation Mechanism of a Charge Modulation Device (CMD) Image Sensor," *IEEE Transaction on Electron Devices, Special Issue on Solid State Image Sensors*, vol. 38, No. 5, pp. 989-998 (May 1991).
- K. Matsumoto, et al., "Analysis of Operational Speed and Scaling Down the Pixel Size of a Charge Modulation Device (CMD) Image Sensor," *IEEE Transaction on Electron Devices, Special Issue on Solid State Image Sensors*, vol. 38, No. 5, pp. 999-1004 (May 1991).
- M. Ogata, "A Small Pixel CMD Image Sensor," *IEEE Transaction on Electron Devices, Special Issue on Solid State Image Sensors*, vol. 38, No. 5, pp. 1005-1010 (May 1991).
- Hyneczek, "BCMD—An Improved Photosite Structure for High-Density Image Sensors," *IEEE Transactions on Electron Devices*, vol. 38(5), pp. 1011-1020 (May 1991).
- T. Mizoguchi, et al., "A 250 k-Pixel SIT Image Sensor Operating in its High-Sensitivity Mode," *IEEE Transaction on Electron Devices, Special Issue on Solid State Image Sensors*, vol. 38, No. 5, pp. 1021-1027 (May 1991).
- Y. Nakamura, et al., "Design of Bipolar Imaging Device (BASIS)," *IEEE Transaction on Electron Devices, Special Issue on Solid State Image Sensors*, vol. 38, No. 5, pp. 1028-1036 (May 1991).
- M. Miyawaki, et al., "Reduction of Fixed-Pattern Noise of BASIS Due to Low Kinetic Energy Reactive Ion to Low Kinetic Energy Reactive Ion and Native-Oxide-Free Processing," *IEEE Transaction on Electron Devices, Special Issue on Solid State Image Sensors*, vol. 38, No. 5, pp. 1037-1043 (May 1991).
- Y. Matsunaga, et al., "A High-Sensitivity MOS Photo-Transistor for Area Image Sensor," *IEEE Transaction on Electron Devices, Special Issue on Solid State Image Sensors*, vol. 38, No. 5, pp. 1044-1047 (May 1991).
- N. Mutoh, et al., "New Low-Noise Output Amplifier for High-Definition CCD Image Sensor," *IEEE Transaction on Electron Devices, Special Issue on Solid State Image Sensors*, vol. 38, No. 5, pp. 1048-10551 (May 1991).
- M. Tabei, et al., "A New CCD Architecture of High-Resolution and Sensitivity for Color Digital Still Picture," *IEEE Transaction on Electron Devices, Special Issue on Solid State Image Sensors*, vol. 38, No. 5, pp. 1052-1058 (May 1991).
- J. Bosiers, et al., "A 2/3-in 1187(H)×581(V) S-VHS-Compatible Frame-Transfer CCD for ESP and Movie Mode," *IEEE Transaction on Electron Devices, Special Issue on Solid State Image Sensors*, vol. 38, No. 5, pp. 1059-1068 (May 1991).
- B. Burke, "An Abutable CCD Imager for Visible and X-Ray Focal Plane Arrays," *IEEE Transaction on Electron Devices, Special Issue on Solid State Image Sensors*, vol. 38, No. 5, pp. 1069-1076 (May 1991).
- E. Garcia, "CCD Arrays for Readout of Electrophotographic Latent Images," *IEEE Transaction on Electron Devices, Special Issue on Solid State Image Sensors*, vol. 38, No. 5, pp. 1077-1085 (May 1991).
- T. Kaneko, et al., "400 dpi Integrated Contact Type Linear Image Sensors with Poly-Si TFT's Analog Readout Circuits and Dynamic Shift Registers," *IEEE Transaction on Electron Devices, Special Issue on Solid State Image Sensors*, vol. 38, No. 5, pp. 1086-1093 (May 1991).
- C. K. Chen, et al., "Ultraviolet, Visible, and Infrared Response of PtSi Schottky-Barrier Detectors Operated in the Front-Illuminated Mode," *IEEE Transaction on Electron Devices, Special Issue on Solid State Image Sensors*, vol. 38, No. 5, pp. 1094-1103 (May 1991).
- R. B. Bailey, et al., "256×256 Hybrid HgCdTe Infrared Focal Plane Arrays," *IEEE Transaction on Electron Devices, Special Issue on Solid State Image Sensors*, vol. 38, No. 5, pp. 1104-1109 (May 1991).
- H. Zogg, et al., "Infrared Sensor Arrays with 3-12 μm Cutoff Wavelengths in Heteroepitaxial Narrow-Gap Semiconductor on Silicon Substrates," *IEEE Transaction on Electron Devices, Special Issue on Solid State Image Sensors*, vol. 38, No. 5, pp. 1110-1117 (May 1991).
- C. G. Bethea, et al., "10-μm GaAs / AlGaAs Multiquantum Well Scanned Array Infrared Imaging Camera," *IEEE Transaction on Electron Devices, Special Issue on Solid State Image Sensors*, vol. 38, No. 5, pp. 1118-1123 (May 1991).
- L. J. Kozlowski, et al., "LWIR 128×128 GaAs / AlGaAs Multiple Quantum Well Hybrid Focal Plane Array," *IEEE Transaction on Electron Devices, Special Issue on Solid State Image Sensors*, vol. 38, No. 5, pp. 1124-1130 (May 1991).
- M. Denda, et al., "4-Band×4096-Element Schottky-Barrier Infrared Linear Image Sensor," *IEEE Transaction on Electron Devices, Special Issue on Solid State Image Sensors*, vol. 38, No. 5, pp. 1131-1135 (May 1991).
- S. Tohyama, et al., "A New Concept Silicon Homojunction Infrared Sensor," *IEEE Transaction on Electron Devices, Special Issue on Solid State Image Sensors*, vol. 38, No. 5, pp. 1136-1140 (May 1991).
- T-L Lin, et al., "SiGe / Si Heterojunction Internal Photoemission Long-Wavelength Infrared Detectors Fabricated by Molecular Beam Epitaxy," *IEEE Transaction on Electron Devices, Special Issue on Solid State Image Sensors*, vol. 38, No. 5, pp. 1141-1144 (May 1991).
- M. Okuyama, et al., "Room-Temperature-Operated Infrared Image CCD Sensor Using Pyroelectric Gate Coupled by Dielectric Connector," *IEEE Transaction on Electron Devices, Special Issue on Solid State Image Sensors*, vol. 38, No. 5, pp. 1145-1151 (May 1991).
- J.G.C. Bakker, "Simple Analytical Expressions for the Fringing Field and Fringing-Field-Induced Transfer Time in Charge-Coupled Devices," *IEEE Transaction on Electron Devices, Special Issue on Solid State Image Sensors*, vol. 38, No. 5, pp. 1152-1161 (May 1991).
- E. K. Banghart, et al., "A Model for Charge Transfer in Buried-Channel Charge-Couple Devices at Low Temperature," *IEEE Transaction on Electron Devices, Special Issue on Solid State Image Sensors*, vol. 38, No. 5, pp. 1162-1174 (May 1991).

- C. R. Hoople, et al., "Characteristics of Submicrometer Gaps in Buried-Channel CCD Structures," *IEEE Transaction on Electron Devices*, Special Issue on Solid State Image Sensors, vol. 38, No. 5, pp. 1175-1181 (May 1991).
- E.R. Fossum, et al., "Two-Dimensional Electron Gas Charge-Coupled Devices (2DEG-CCD's)," *IEEE Transaction on Electron Devices*, Special Issue on Solid State Image Sensors, vol. 38, No. 5, pp. 1182-1192 (May 1991).
- J.G.C. Bakker, et al., "The Tacking CCD: A New CCD Concept," *IEEE Transaction on Electron Devices*, Special Issue on Solid State Image Sensors, vol. 38, No. 5, pp. 1193-1200 (May 1991).
- S. Takayama, et al., "A Dynamic Model of an a-Si:H Photoconductive Sensor," *IEEE Transaction on Electron Devices*, Special Issue on Solid State Image Sensors, vol. 38, No. 5, pp. 1201-1205 (May 1991).
- P. Centen, "CCD On-Chip Amplifiers: Noise Performance versus MOS Transistor Dimensions," *IEEE Transaction on Electron Devices*, Special Issue on Solid State Image Sensors, vol. 38, No. 5, pp. 1206-1216 (May 1991).
- N. Ozawa, et al., "A Correlative Coefficient Multiplying (CCM) Method for Chrominance Moire Reduction in Single-Chip Color Video Cameras," *IEEE Transaction on Electron Devices*, Special Issue on Solid State Image Sensors, vol. 38, No. 5, pp. 1217-1225 (May 1991).
- Y.T. Tsai, "Color Image Compression for Single-Chip Cameras," *IEEE Transaction on Electron Devices*, Special Issue on Solid State Image Sensors, vol. 38, No. 5, pp. 1226-1232 (May 1991).
- P. Noble, "Self-Scanned Silicon Image Detector Arrays," *IEEE Trans. on Electron Devices*, vol. ED-15, No. 4, pp. 202-209 (Apr. 1968).
- J. Nishizawa, et al., "Static Induction Transistor Image Sensors," *IEEE Trans. on Electron Devices*, vol. ED-26 (12), pp. 1970-1977 (Dec. 1979).
- K. Matsumoto, et al., "A New MOS Phototransistor Operating in a Non-Destructive Readout Mode," *Jpn. J. Appl. Phys.*, vol. 24, No. 5, pp. L323-L325 (1985).
- H. Ando, et al., "Design Consideration and Performance of a New MOS Imaging Device," *IEEE Trans. on Electron Devices*, vol. ED-32, No. 8, pp. 1484-1489 (Aug. 1985).
- T. Nakamura, et al., "A New MOS Image Sensor Operating in a Non-Destructive Readout Mode," *IEDM Tech. Dig.*, pp. 353-356 (1986).
- A. Yusa, et al., "SIT Image Sensor: Design Considerations and Characteristics" *IEEE Trans. on Electron Devices*, vol. ED-33, No. 6, pp. 735-742 (Jun. 1986).
- N. Tanaka, et al. "A Novel Bipolar Image Device with Self-Noise-Reduction Capability," *IEEE Trans. on Electron Devices*, vol. 36(1), pp. 31-38 (Jan. 1989).
- Z. Huang, et al., "A Novel Amplified Image Sensor with a-Si:H Photoconductor and MOS Transistor," *IEEE Trans. on Electron Devices*, vol. 37, No. 6, pp. 1432-1438 (Jun. 1990).
- Y. Nakamura, et al., "Design of Bipolar Imaging Devices (BASIS): Analysis of Random Noise," *IEEE Trans. on Electron Devices*, vol. 39(6), pp. 1341-1349 (Jun. 1992).
- E. Fossum, "Active-pixel sensors challenge CCDs," *Laser Focus World*, vol. 29, pp. 83-87 (Jun. 1993).
- S. Mendis, et al., "A 128x128 CMOS Active Pixel Image Sensor for Highly Integrated Imaging Systems," *Proc. of the 1993 IEEE International Electron Devices Meeting*, pp. 583-586 (1993).
- S. Mendis, et al., "Progress in CMOS Active Pixel Image Sensors," *Proc. SPIE*, vol. 2172, pp. 19-29 (1994).
- S. Mendis, et al., "CMOS Active Pixel Image Sensor," *IEEE Trans. on Electron Devices*, vol. 41, No. 3, pp. 452-453 (Mar. 1994).
- T. Kinugasa, et al., "An Electronic Variable-Shutter System in Video Camera Use," *IEEE Transactions on Consumer Electronics*, vol. CE-33, No. 3, pp. 249-255 (1987).
- S. Mendis, et al., "CMOS Active Pixel Image Sensor," Citation Unknown, pp. 1-7 (Jul. 1993).

* cited by examiner

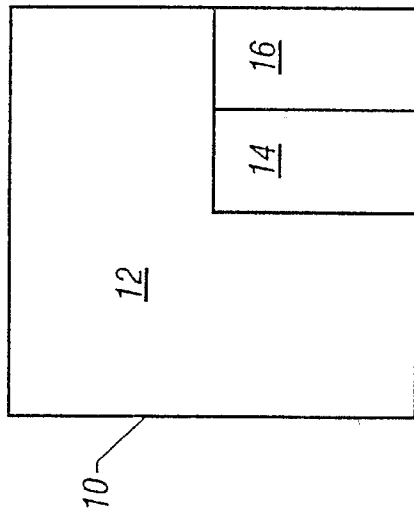

FIG. 1

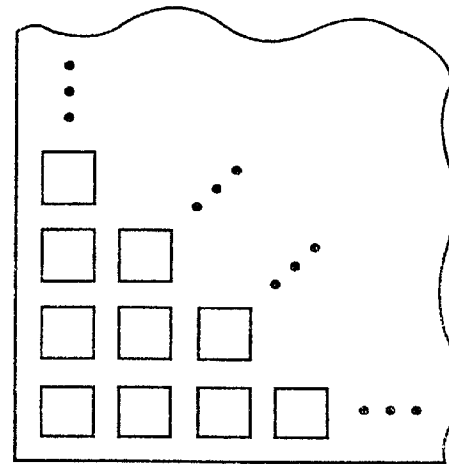

FIG. 2

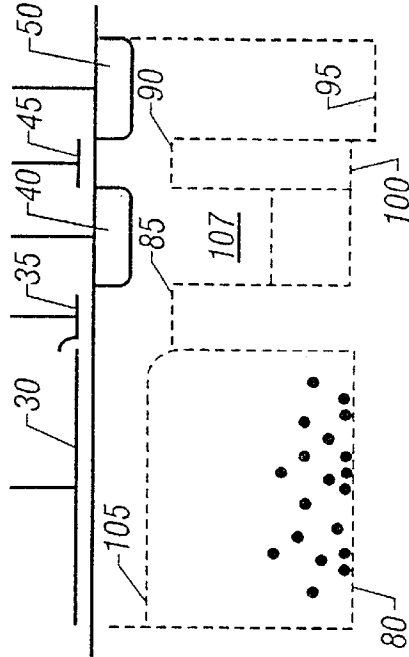

FIG. 4

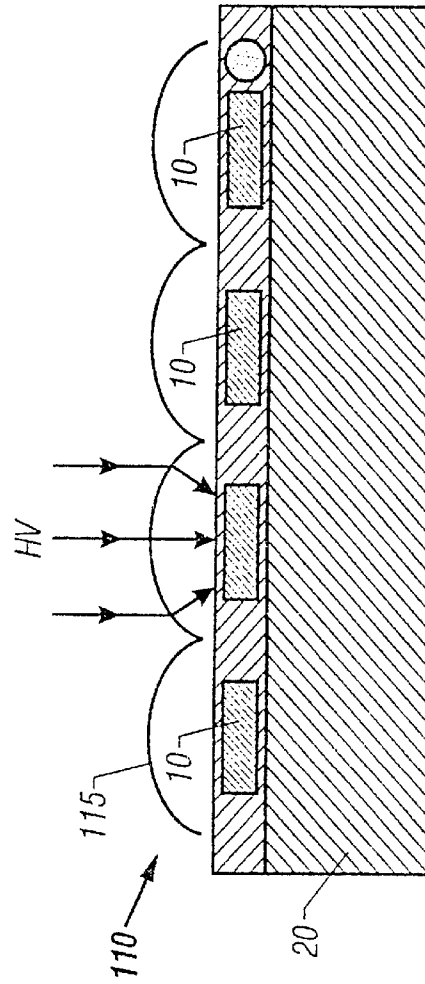

FIG. 5

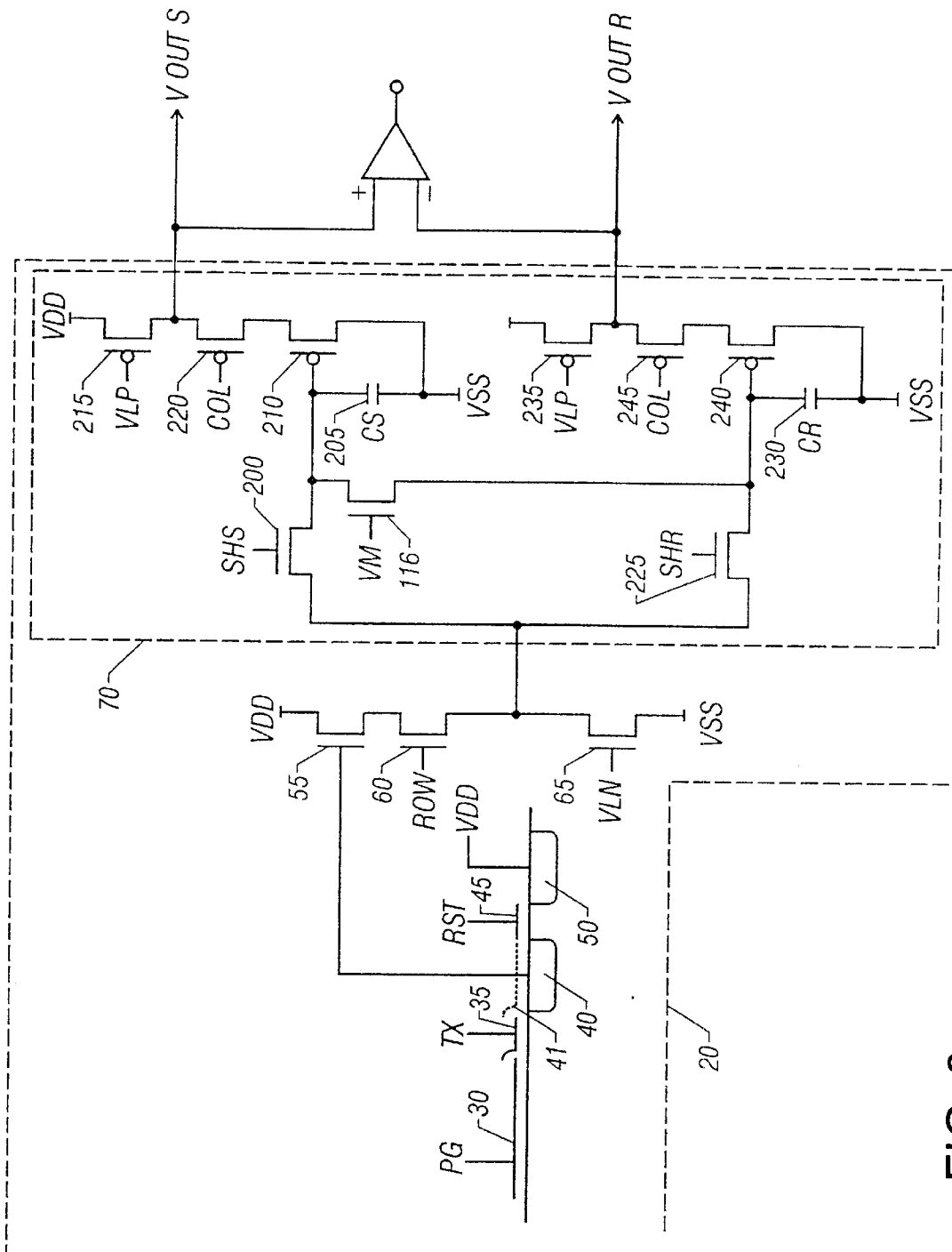

FIG. 3

ACTIVE PIXEL SENSOR WITH INTRA-PIXEL CHARGE TRANSFER

This application is a continuation of Ser. No. 08/558,521 filed Nov. 16, 1995 U.S. Pat. No. 6,101,232 which is a continuation of Ser. No. 08/188,032 filed Jan. 28, 1994 U.S. Pat. No. 5,471,515.

ORIGIN OF THE INVENTION

The invention described herein was made in the performance of work under a NASA contract, and is subject to the provisions of Public Law 96-517 (35 USC 202) in which the Contractor has elected to retain title.

BACKGROUND OF THE INVENTION

1. Technical Field

The invention is related to semiconductor imaging devices and in particular to a silicon imaging device which can be fabricated using a standard CMOS process.

2. Background Art

There are a number of types of semiconductor imagers, including charge coupled devices, photodiode arrays, charge injection devices and hybrid focal plane arrays. Charge coupled devices enjoy a number of advantages because they are an incumbent technology, they are capable of large formats and very small pixel size and they facilitate noiseless charge domain processing techniques (such as binning and time delay integration). However, charge coupled device imagers suffer from a number of disadvantages. For example, they exhibit destructive signal read-out and their signal fidelity decreases as the charge transfer efficiency raised to the power of the number of stages, so that they must have a nearly perfect charge transfer efficiency. They are particularly susceptible to radiation damage, they required good light shielding to avoid smear and they have high power dissipation for large arrays.

In order to ameliorate the charge transfer inefficiency problem, charge coupled device (CCD) imagers are fabricated with a specialized CCD semiconductor fabrication process to maximize their charge transfer efficiency. The difficulty is that the standard CCD process is incompatible with complementary metal oxide semiconductor (CMOS) processing, while the image signal processing electronics required for the imager are best fabricated in CMOS. Accordingly, it is impractical to integrate on-chip signal processing electronics in a CCD imager. Thus, the signal processing electronics is off-chip. Typically, each column of CCD pixels is transferred to a corresponding cell of a serial output register, whose output is amplified by a single on-chip amplifier (e.g., a source follower transistor) before being processed in off-chip signal processing electronics. As a result, the read-out frame rate is limited by the rate at which the on-chip amplifier can handle charge packets divided by the number of pixels in the imager.

The other types of imager devices have problems as well. Photodiode arrays exhibit high noise due to so-called kTC noise which makes it impossible to reset a diode or capacitor node to the same initial voltage at the beginning of each integration period. Photodiode arrays also suffer from lag. Charge injection devices also suffer from high noise, but enjoy the advantage of non-destructive readout over charge coupled devices.

Hybrid focal plane arrays exhibit less noise but are prohibitively expensive for many applications and have relatively small array sizes (e.g., 512-by-512 pixels).

What is needed is an imager device which has the low kTC noise level of a CCD without suffering from the destructive readout tendencies of a CCD.

SUMMARY OF THE DISCLOSURE

The invention is embodied in an imaging device formed as a monolithic complementary metal oxide semiconductor integrated circuit in an industry standard complementary metal oxide semiconductor process, the integrated circuit including a focal plane array of pixel cells, each one of the cells including a photogate overlying the substrate for accumulating photo-generated charge in an underlying portion of the substrate, a readout circuit including at least an output field effect transistor formed in the substrate, and a charge coupled device section formed on the substrate adjacent the photogate having a sensing node connected to the output transistor and at least one charge coupled device stage for transferring charge from the underlying portion of the substrate to the sensing node.

In a preferred embodiment, the sensing node of the charge coupled device stage includes a floating diffusion, and the charge coupled device stage includes a transfer gate overlying the substrate between the floating diffusion and the photogate. This preferred embodiment can further include apparatus for periodically resetting a potential of the sensing node to a predetermined potential, including a drain diffusion connected to a drain bias voltage and a reset gate between the floating diffusion and the drain diffusion, the reset gate connected to a reset control signal.

Preferably, the output transistor is a field effect source follower transistor, the floating diffusion being connected to a gate of the source follower transistor. Preferably, the readout circuit further includes a double correlated sampling circuit having an input node connected to the output transistor. In the preferred implementation, the double correlated sampling circuit samples the floating diffusion immediately after it has been reset at one capacitor and then, later, at the end of the integration period at another capacitor. The difference between the two capacitors is the signal output. In accordance with a further refinement, this difference is corrected for fixed pattern noise by subtracting from it another difference sensed between the two capacitors while they are temporarily shorted.

BRIEF DESCRIPTION OF THE DRAWINGS

FIG. 1 is a diagram illustrating the architecture of an individual focal plane cell of the invention.

FIG. 2 is a plan view of an integrated circuit constituting a focal plane array of cells of the type illustrated in FIG. 1.

FIG. 3 is a schematic diagram of the cell of FIG. 1.

FIG. 4 is a graph of the surface potential in the charge transfer section of the cell of FIG. 3.

FIG. 5 is a cross-sectional view of an alternative embodiment of the focal plane array of FIG. 2 including a microlens layer.

DETAILED DESCRIPTION OF THE PREFERRED EMBODIMENTS

FIG. 1 is a simplified block diagram of one pixel cell 10 of a focal plane array of many such cells formed in an integrated circuit. Each cell 10 includes a photogate 12, a charge transfer section 14 adjacent the photogate 12 and a readout circuit 16 adjacent the charge transfer section 14. FIG. 2 shows a focal plane array of many cells 10 formed on a silicon substrate 20. FIG. 3 is a simplified schematic dia-

gram of a cell 10. Referring to FIG. 3, the photogate 12 consists of a relative large photogate electrode 30 overlying the substrate 20. The charge transfer section 14 consists of a transfer gate electrode 35 adjacent the photogate electrode 30, a floating diffusion 40, a reset electrode 45 and a drain diffusion 50. The readout circuit 16 consists of a source follower field effect transistor (FET) 55, a row select FET 60, a load FET 65 and a correlated double sampling circuit 70.

Referring to the surface potential diagram of FIG. 4, the photogate electrode 30 is held by a photogate signal PG at a positive voltage to form a potential well 80 in the substrate 20 in which photo-generated charge is accumulated during an integration period. The transfer gate electrode 35 is initially held at a less positive voltage by transfer gate signal TX to form a potential barrier 85 adjacent the potential well 80. The floating diffusion 40 is connected to the gate of the source follower FET 55 whose drain is connected to a drain supply voltage VDD. The reset electrode 45 is initially held by a reset signal RST at a voltage corresponding to the voltage on the transfer gate 35 to form a potential barrier 90 thereunder. The drain supply voltage VDD connected to the drain diffusion 50 creates a constant potential well 95 underneath the drain diffusion 50.

During the integration period, electrons accumulate in the potential well 80 in proportion to photon flux incident on the substrate 20 beneath the photogate electrode 30. At the end of the integration period, the surface potential beneath the floating diffusion 40 is quickly reset to a potential level 100 slightly above the potential well 95. This is accomplished by the reset signal RST temporarily increasing to a higher positive voltage to temporarily remove the potential barrier 90 and provide a downward potential staircase from the transfer gate potential barrier 85 to the drain diffusion potential well 95, as indicated in the drawing of FIG. 4. After the reset gate 45 is returned to its initial potential (restoring the potential barrier 90), the readout circuit 70 briefly samples the potential of the floating diffusion 40, and then the cell 10 is ready to transfer the photo-generated charge from beneath the photogate electrode 30. For this purpose, the photogate signal PG decreases to a less positive voltage to form a potential barrier 105 beneath the photogate electrode 30 and thereby provide a downward staircase surface potential from the photogate electrode 30 to the potential well 100 beneath the floating diffusion 40. This transfers all of the charge from beneath the photogate electrode 30 to the floating diffusion 40, changing the potential of the floating diffusion 40 from the level (100) at which it was previously reset to a new level 107 indicative of the amount of charge accumulated during the integration period. This new potential of the floating diffusion 40 is sensed at the source of the source follower FET 55. However, before the readout circuit 70 samples the source of the source follower FET 55, the photogate signal PG returns to its initial (more positive) voltage. The entire process is repeated for the next integration period.

The readout circuit 70 consists of a signal sample and hold (S/H) circuit including an S/H FET 200 and a signal store capacitor 205 connected through the S/H FET 200 and through the row select FET 60 to the source of the source follower FET 55. The other side of the capacitor 205 is connected to a source bias voltage VSS. The one side of the capacitor 205 is also connected to the gate of an output FET 210. The drain of the output FET is connected through a column select FET 220 to a signal sample output node VOUTS and through a load FET 215 to the drain voltage VDD. A signal called "signal sample and hold" (SHS)

briefly turns on the S/H FET 200 after the charge accumulated beneath the photogate electrode 30 has been transferred to the floating diffusion 40, so that the capacitor 205 stores the source voltage of the source follower FET 55 indicating the amount of charge previously accumulated beneath the photogate electrode 30.

The readout circuit 70 also consists of a reset sample and hold (S/H) circuit including an S/H FET 225 and a signal store capacitor 230 connected through the S/H FET 225 and through the row select FET 60 to the source of the source follower FET 55. The other side of the capacitor 230 is connected to the source bias voltage VSS. The one side of the capacitor 230 is also connected to the gate of an output FET 240. The drain of the output FET 240 is connected through a column select FET 245 to a reset sample output node VOUTR and through a load FET 235 to the drain voltage VDD. A signal called "reset sample and hold" (SHR) briefly turns on the S/H FET 225 immediately after the reset signal RST has caused the resetting of the potential of the floating diffusion 40, so that the capacitor 230 stores the voltage at which the floating diffusion has been reset to.

The readout circuit provides correlated double sampling of the potential of the floating diffusion, in that the charge integrated beneath the photogate 12 each integration period is obtained at the end of each integration period from the difference between the voltages at the output nodes VOUTS and VOUTR of the readout circuit 70. This eliminates the effects of kTC noise because the difference between VOUTS and VOUTR is independent of any variation in the reset voltage RST, a significant advantage.

Referring to FIG. 5, a transparent refractive microlens layer 110 may be deposited over the top of the focal plane array of FIG. 2. The microlens layer 110 consists of spherical portions 115 centered over each of the cells 10 and contoured so as to focus light toward the center of each photogate 12. This has the advantage of using light that would otherwise fall outside of the optically active region of the photogate 12. For example, at least some of the light ordinarily incident on either the charge transfer section 14 or the readout circuit 16 (FIG. 1) would be sensed in the photogate area with the addition of the microlens layer 110.

Preferably, the focal plane array corresponding to FIGS. 1-4 is implemented in CMOS silicon using an industry standard CMOS fabrication process. Preferably, each of the FETs is a MOSFET, the FETs 55, 60, 65, 200 and 225 being n-channel devices and the FETs 210, 220, 225, 230, 240, 245 being p-channel devices. The n-channel MOSFETs and the CCD channel underlying the gate electrodes 30, 35, 45 and the diffusions 40 and 50 may be located in a p-well while the remaining (p-channel) devices are located outside of the p-well. The gate voltage VLP applied to the gates of the p-channel load FETs 215 and 235 is a constant voltage on the order of +2.5 volts. The gate voltage VLN applied to the n-channel load FET 65 is a constant voltage on the order of +1.5 volts.

Since the charge transfer section 14 involves only a single CCD stage between the photogate 12 and the floating diffusion 40 in the specific embodiment of FIG. 3, there is no loss due to charge transfer inefficiency and therefore there is no need to fabricate the device with a special CCD process. As a result, the readout circuit 70 as well as the output circuitry of the FETs 55, 60 and 65 can be readily implemented as standard CMOS circuits, making them extremely inexpensive. However, any suitable charge coupled device architecture may be employed to implement the charge transfer section 14, including a CCD having more

than one stage. For example, two or three stages may be useful for buffering two or three integration periods.

Other implementations of the concept of the invention may be readily constructed by the skilled worker in light of the foregoing disclosure. For example, the floating diffusion **40** may instead be a floating gate electrode. The signal and reset sample and hold circuits of the readout circuit **70** may be any suitable sample and hold circuits. Moreover, shielding of the type well-known in the art may be employed defining an aperture surrounding the photogate **12**. Also, the invention may be implemented as a buried channel device.

Another feature of the invention which is useful for eliminating fixed pattern noise due to variations in FET threshold voltage across the substrate **20** is a shorting FET **116** across the sampling capacitors **205**, **235**. After the accumulated charge has been measured as the potential difference between the two output nodes VOUTS and VOUTR, a shorting signal VM is temporarily applied to the gate of the shorting FET **116** and the VOUTS-to-VOUTR difference is measured again. This latter difference is a measure of the disparity between the threshold voltages of the output FETs **210**, **240**, and may be referred to as the fixed pattern difference. The fixed pattern difference is subtracted from the difference between VOUTS and VOUTR measured at the end of the integration period, to remove fixed pattern noise.

As previously mentioned herein, a floating gate may be employed instead of the floating diffusion **40**. Such a floating gate is indicated schematically in FIG. **3** by a simplified dashed line floating gate electrode **41**.

Preferably, the invention is fabricated using an industry standard CMOS process, so that all of the dopant concentrations of the n-channel and p-channel devices and of the various diffusions are in accordance with such a process. In one implementation, the area of the L-shaped photogate **12** (i.e., the photogate electrode **30**) was about 100 square microns; the transfer gate electrode **35** and the reset gate electrode were each about 1.5 microns by about 6 microns; the photogate signal PG was varied between about +5 volts (its more positive voltage) and about 0 volts (its less positive voltage); the transfer gate signal TX was about +2.5 volts; the reset signal RST was varied between about +5 volts (its more positive voltage) and about +2.5 volts (its less positive voltage); the drain diffusion **50** was held at about +5 volts.

While the invention has been described in detail by specific reference to preferred embodiments, it is understood that variations and modifications may be made without departing from the true spirit and scope of the invention.

What is claimed is:

1. An imaging device including a monolithic semiconductor integrated circuit substrate, said imaging device comprising a focal plane array of pixel cells, each of said cells comprising:

- a photoreceptor, adjacent said substrate, to control accumulating photo-generated charge
- a readout circuit comprising at least a buffering transistor and a selecting transistor, formed in said substrate;
- a coupling section formed on said substrate adjacent said photoreceptor, having a sensing node connected to said output transistor and at least one coupling stage for transferring said photogenerated charge to said sensing node; and

wherein said transistors in said readout circuit are formed of an integrated circuit technology which is compatible with complimentary metal oxide semiconductor (CMOS) technology, formed on said substrate, said

substrate being of a first conductivity type, said readout circuit comprising transistors of a first conductivity type, a well region of a second conductivity type in said substrate and plural semiconductor transistors of a second conductivity type formed in said well region.

2. An imaging device as in claim **1**, further comprising a microlens layer formed on at least part of the substrate to refract light incident on an area of the substrate that includes circuitry including at least said readout circuit, to the photoreceptor.

3. An imaging device comprising a focal plane array of pixel cells, each of said pixel cells including a monolithic semiconductor integrated circuit substrate, each of said pixel cells comprising:

- a photoreceptor overlying a first portion of said substrate and operating to accumulate photo-generated charge in the first portion of said substrate that underlies said photogate;
- a charge transfer section, formed in said substrate adjacent said photogate, having a sensing node adjacent said photoreceptor and at least one charge coupling stage, operating to transfer charge from said first portion of said substrate to said sensing node; and
- a readout circuit connected to said sensing node and to no other sensing node of any other one of said pixel cells, so that said readout circuit of each said one of said pixel cells is associated with only one photoreceptor and only one charge transfer section, said readout circuit including at least a buffering transistor and a selection transistor.

4. The imaging device of claim **3** wherein:

said sensing node of said charge transfer section stage comprises a floating node; and

said charge coupling stage comprises a transfer gate between said floating node and said photogate.

5. The imaging device of claim **4** wherein said floating node is one of: (a) a floating diffusion, and (b) a floating gate.

6. An imaging device as in claim **3**, wherein said readout circuit includes a sampling element which stores the charge received from said substrate, and a shorting element which shorts across the sampling element after the charge is read.

7. A device as in claim **6**, wherein said sampling element is a capacitor and said shorting element is a shorting FET.

8. An imaging device as in claim **3**, wherein said readout circuit is formed of an integrated circuit technology which is compatible with complimentary metal oxide semiconductor (CMOS) technology.

9. An imaging device, comprising:

- a substrate of a type which can store optical charge therein, said substrate formed of a plurality of pixel cells, each pixel cell comprising:
 - an optical charge storage section, including a photoreceptor;
 - a charge transfer section, having a sensing node, and having a first state in which charge from the photoreceptor is isolated from the sensing node and a second state in which charge from the photoreceptor is coupled to said sensing node; and
 - a readout circuit, having an input connected to said sensing node, said readout circuit connected to no other nodes of any of the other pixel cells of the device so that each optical charge storage section and charge transfer section is associated with only one readout circuit.

10. A device as in claim **9**, wherein said sensing node of said charge transfer section includes a first floating element, which is initially isolated from charge and is later coupled to the charge.

11. An device as in claim 10, wherein said readout circuit includes a first sampling element for sampling an initial potential on the first floating element while said charge transfer section is isolated from said first floating element, and a second sampling element for sampling a later potential on said floating element when said charge transfer section is coupled to the first floating element.

12. A device as in claim 11, wherein said readout circuit includes double sampling circuitry subtracting said initial potential from said later potential to produce a difference, and wherein an output of said readout circuit is proportional to the difference.

13. A device as in claim 12, wherein said sampling elements comprise capacitors.

14. A device as in claim 9, wherein said readout circuit includes an input node to the readout circuit which is directly connected to the sensing node of said charge transfer section, said input node including a follower circuit.

15. A device as in claim 9, further comprising a microlens layer formed on at least part of the substrate to refract light incident on an area of the substrate that includes circuitry including at least said readout circuit, to the optical charge storage section.

16. An imaging device as in claim 9, wherein said readout circuit is formed of an integrated circuit technology which is compatible with complimentary metal oxide semiconductor (CMOS) technology.

17. An imaging device, comprising:

- a focal plane array of pixel cells, including a substrate of a type which can store optical charge therein;
- each pixel cell formed in a predetermined area of said substrate, and comprising:
 - an optical charge storage section, including a photoreceptor overlying a first portion of said predetermined area of said substrate which accumulates charge therein;

- a plurality of circuitry elements, formed in a second portion of said predetermined area; and
- a microlens, overlying at least said second portion, and directing light impinging on said second portion to said first portion.

18. An imaging device as in claim 17, wherein said plurality of circuitry elements comprises:

- a charge transfer section, having a sensing node, and having a first state in which charge in the substrate is isolated from the sensing node and a second state in which charge in the substrate is coupled to said sensing node; and
- a readout circuit, having an input connected to said sensing node, said readout circuit connected to no other nodes of any of the other pixel cells of the device so that each optical charge storage section and charge transfer section is associated with only one readout circuit.

19. An imaging device including a monolithic semiconductor integrated circuit substrate, said imaging device comprising a focal plane array of pixel cells, each one of said cells comprising:

- a photosensor coupled to said substrate, and accumulating photo-generated charge in said substrate;
- a readout circuit comprising at least a select transistor and a buffering transistor, formed in said substrate;
- a coupling section, formed on said substrate adjacent said photogate, having a sensing node connected to said output transistor and at least one coupling stage which transfers charge from said underlying portion of said substrate to said sensing node.

* * * * *